

Main spindle	
Power	29.5kW
Max. torque	70.4/88.3Nm
Max. speed	18,000 rpm.
Tool system	HSK A63
C-Axis	
Max torque	1,000Nm
Braking torque	1,250Nm(65bar)
Swiveling speed	40°/s(6.67rpm.)
Rotary angle	+/-220°
A-Axis	
Max torque	1,000Nm
Braking torque	1,250Nm(65bar)
Swiveling speed	40°/s(6.67rpm.)
Swiveling angle	+/-105°

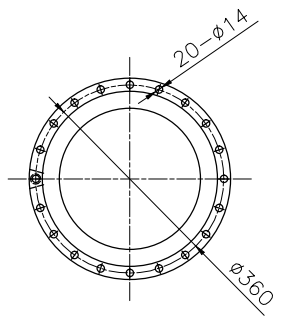

View W

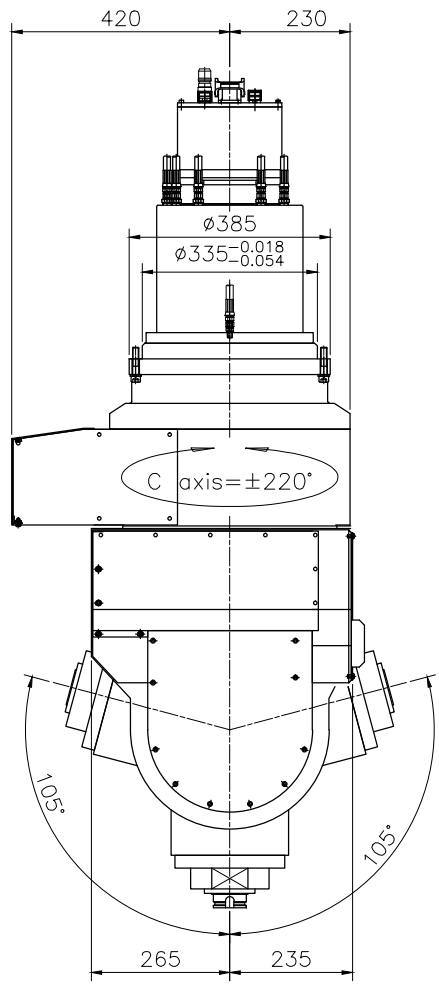
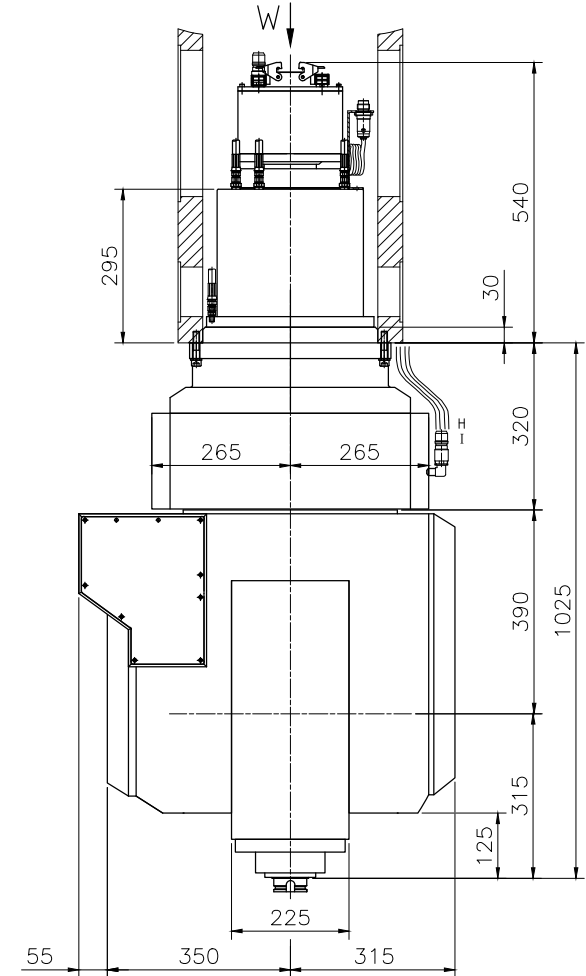
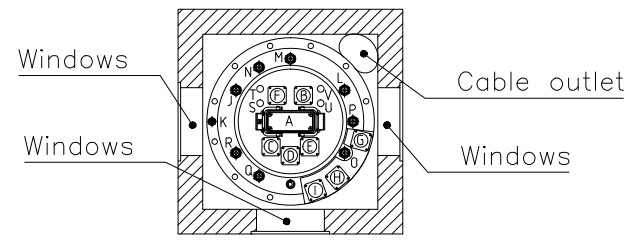

Electrical Parts	
A	Spindle motor power cable & Ground cable
B	Spindle piston sensor
	Spindle tool sensor
	Spindle front temp. sensor
	Spindle rear temp. sensor
C	Spindle encoder cable
D	A-Axis encoder cable
E	A-Axis motor cable
F	A-Axis motor power cable
G	C-Axis encoder cable
H	C-Axis motor cable
I	C-Axis motor power cable
Mechanical parts	
J	Tool unclamping
K	C -Axis clamping
L	A -Axis clamping
M	Spindle cooling (in)
N	Spindle cooling (out)
O	C -Axis cooling (in)
P	C -Axis cooling (out)
Q	External coolant
R	Rotating union(C.T.S.)
S	Bearing lubrication(Front)
T	Bearing lubrication(Rear)
U	Air seal
V	Suction

PERMISSIBLE MACHING BASIC DIMENSION DEVIATIONS					
>0	>6	>30	>120	>400	>1000
±0.05	±0.10	±0.15	±0.20	±0.30	±0.50
PERMISSIBLE DRILLING BASIC DIMENSION DEVIATIONS					+0.25 -0.05
PERMISSIBLE ANGLE BASIC DIMENSION DEVIATIONS					±0.5°

DRAWN		
DESIGNED		
CHECKED		
MATERIAL		
SCALE	1:15	

NAME	
DWG.NO. C66M01-WEA	

ver.	coordinates	Changing content	Modified by	date
------	-------------	------------------	-------------	------