

AHC VERTICAL EXTENSION HEAD SPEC.	
Tool interface	ISO50 DIN Automatic
Spindle gear	40 kW
Spindle speed	2,000 rpm
Spindle torque	2,500 Nm
Spindle rotation	By Ram
Work position	Vertical
Coolant	INT 20 bar (CTS)
	EST 4/6 bar
Air pressure	6 bar
Tool clamping	Automatic
Head clamping	Automatic
Tool clamping force	2,400 kgf
Volume (LxWxH)	650x650x870mm

3:Cutting coolant
5:Front bearing air seal
11:Tool clamping
12:Tool unclamping

NOTE:
1.The 3rd hole use of fluid quick connector male end specifications for SPC-12
2.On the 5th, the 11th, the 12th hole use of fluid quick connector male end specifications for SPC-08

ver.	coordinates	Changing content	Modified by	date

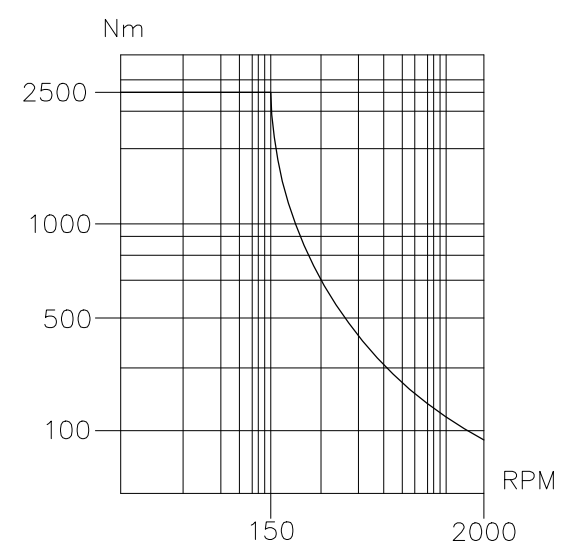
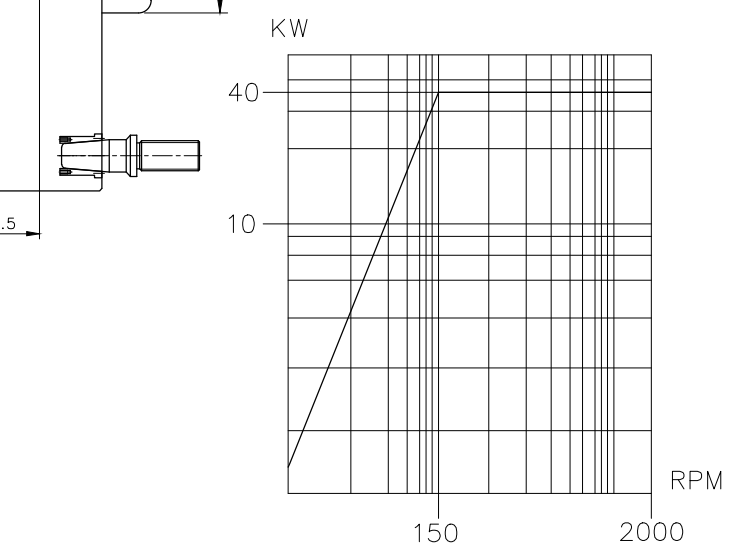

PERMISSIBLE MACHING BASIC DIMENSION DEVIATIONS						DRAWN		NAME
>0	>6	>30	>120	>400	>1000	DESIGNED		
±0.05	±0.10	±0.15	±0.20	±0.30	±0.50	CHECKED		
PERMISSIBLE DRILLING BASIC DIMENSION DEVIATIONS						+0.25	MATERIAL	DWG.NO.
						-0.05		
PERMISSIBLE ANGLE BASIC DIMENSION DEVIATIONS						±0.5°	SCALE	A62F01-ACA-CT

