

Spindle key &
Transmission ring
Mutually perpendicular

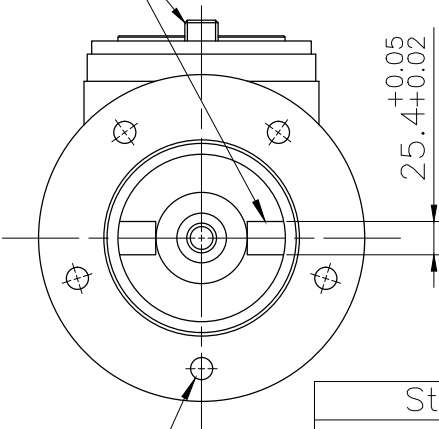

VERTICAL AND HORIZONTAL MILLING HEAD SINGLE SPEC	
Tool interface	MAS#50 7/24Taper
Spindle speed	2,000 rpm
Tool clamp mechanism	M24 Bolt
Bevel gear Lubricate	OIL(NBU15)
Gear ratio	1 : 1
Max transmission power	11 kW
Volume(LxWxH)	360.5x250x551.8mm
Weight	100 kg

Standard accessories	
Double tooth studs,nuts,washers	M14x70L-Five sets
Broach bolt/hex wrench	M24x215L Bolt/19mm
Storage methods	Metal box

PERMISSIBLE MACHING BASIC DIMENSION DEVIATIONS					
>0	>6	>30	>120	>400	>1000
±0.05	±0.10	±0.15	±0.20	±0.30	±0.50

PERMISSIBLE DRILLING BASIC DIMENSION DEVIATIONS	
+0.25	-0.05

PERMISSIBLE ANGLE BASIC DIMENSION DEVIATIONS	
±0.5°	

DRAWN		
DESIGNED		
CHECKED		
MATERIAL		
SCALE	1:6	

NAME	
DWG.NO. X57S01	

ver.	coordinates	Changing content	Modified by	date
------	-------------	------------------	-------------	------