

Precision Dovetail Slides

- *DS Series • TS Series • M Series*
- *Slide Widths from 2"–16"*

MASTER[™]
SETCO

DS Series

Introducing the DS Family of MASTER/SETCO Dovetail Slides

Express DS Series

- **One week shipment!**

The Express DS Slide Series is for applications where compact design and immediate delivery are essential. Available in the most popular sizes of 4", 6", 8", 10" or 12" base widths, they are factory assembled from off-the-shelf components and shipped to you ready to install.

Shipment is within one week after order placement. For multiple quantities of slides, consult factory for delivery.



Express DS Basic Model

Select DS Series

- **Wide range of sizes and accessories.**
- **Shipments as short as three weeks.**

The Select DS Slide Series offers you a wider choice in drive styles, accessories and sizes. Base and saddle lengths are available in 1" increments up to 64".

Ideal for use in work feeders, positioning fixtures, workholding devices, shuttle devices and assembly equipment, Select DS Slides are factory assembled, tested and shipped to you ready to install.

Shipment is within three to five weeks from the time your order is placed. For multiple quantities of slides, consult factory for delivery.

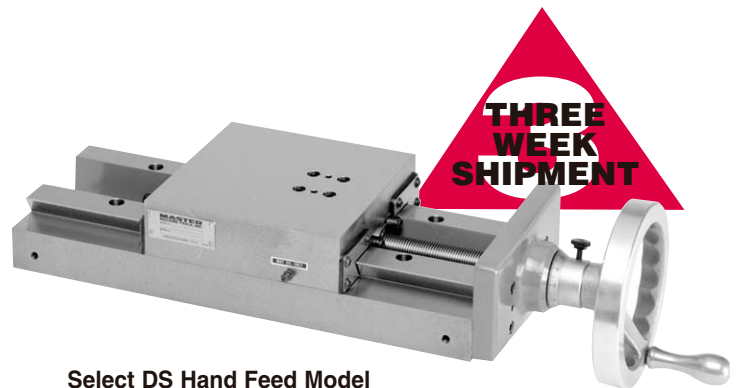

Select DS Hand Feed Model With Feedscrew

Super Select DS Series

- **Engineered around a standard product building block.**
- **Allows modification to meet your application requirements.**
- **Reduces excessive leadtime and cost premiums.**

The Super Select DS Slide Series is designed around a standard baseline platform. Such a modular design allows our Team of Solutions Engineers the flexibility to create a slide that will virtually match your application needs in size and capability...but without excessive leadtimes and cost premiums that are often associated with custom designed slides.

All Super Select slides are factory engineered, manufactured, assembled, runoff and shipped to you ready to install. Leadtime is contingent on the complexity of your slide design.

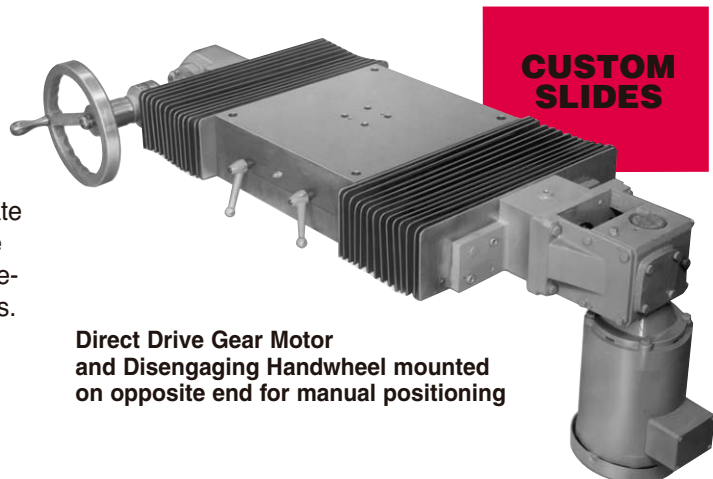

Direct Drive Gear Motor and Disengaging Handwheel mounted on opposite end for manual positioning

NOTE: Due to continual improvements, specifications are subject to change without notice. For current specifications, request a certified print when placing your order.
© 2004 SETCO® and MASTER/SETCO™ are trademarks of SETCO Sales Company.

Quick-Reference Index

Precision Slide Solutions

“DS” Series Dovetail Slides

- *100% Solid Model Design*

This state-of-the-art dovetail slide is an ideal choice for assembly, test, gauge, motion control and machining applications. Available in the most popular sizes of base widths, DS slides are factory assembled from off-the-shelf components and shipped to you ready to install. Three distinct DS Series are available:

- **Express DS** – Shipment in **one week** on basic and hand feed models. Base widths are available in 4", 6", 8", 10" and 12".
- **Select DS** – Shipment in **three to five weeks**. Widths to 16". Lengths in 1" increments to 64". Available with a wider range of drive styles and accessories.
- **Super Select DS** – Everything you want in a custom slide – built right in.

Off-The-Shelf Standard and Heavy Duty “TS” Series Dovetail Slides

- *“TS” Series Extended Saddle*

The reliable TS Series is an excellent tool slide choice when you have precision positioning, feeding, gauging, inspection or lathe applications. Designed with an extended saddle, these rugged cast-iron slides provide increased reach with reduced interference. The standard duty low profile TS includes 2" through 6" wide bases. A heavier duty high profile HTS model offers increased load capacity and base widths up to 8".

In-Stock “M” Series Dovetail Slides

- *Includes Hand Feed Package*

With in stock availability, the M Series is your ideal choice for no-wait replacement of current M slides, or for replacing other designs that require compounding or angle plate mounting. The reliable M Series is well-suited for your new slide designs that can adapt to pre-engineered sizes. The saddle and base come pre-drilled for quick assembly. A wide variety of standard attachments, such as angle plates, rotary swivel tables, accordion way covers and right angle drives, are available to meet diverse requirements. Width sizes range from 2" to 10".

DS
SERIES SLIDES

Page
4

EXPRESS DS

Page **6**

SELECT DS

Page **11**

SUPER SELECT DS

Page **17**

TS
SERIES SLIDES

Page
23

M
SERIES SLIDES

Page
34

M SERIES
APPLICATION PHOTOS

Page **46**

Design
Data

Page
50

To Place Your Order
Phone: 1-800-543-0470 Fax: 1-513-941-6913
Email: sales@setcousa.com

Express DS

- One Week Shipment
- Five Pre-Engineered Base Widths to 12"
- 100% Solid Model Design
- Ideal for Applications Requiring Compact Size

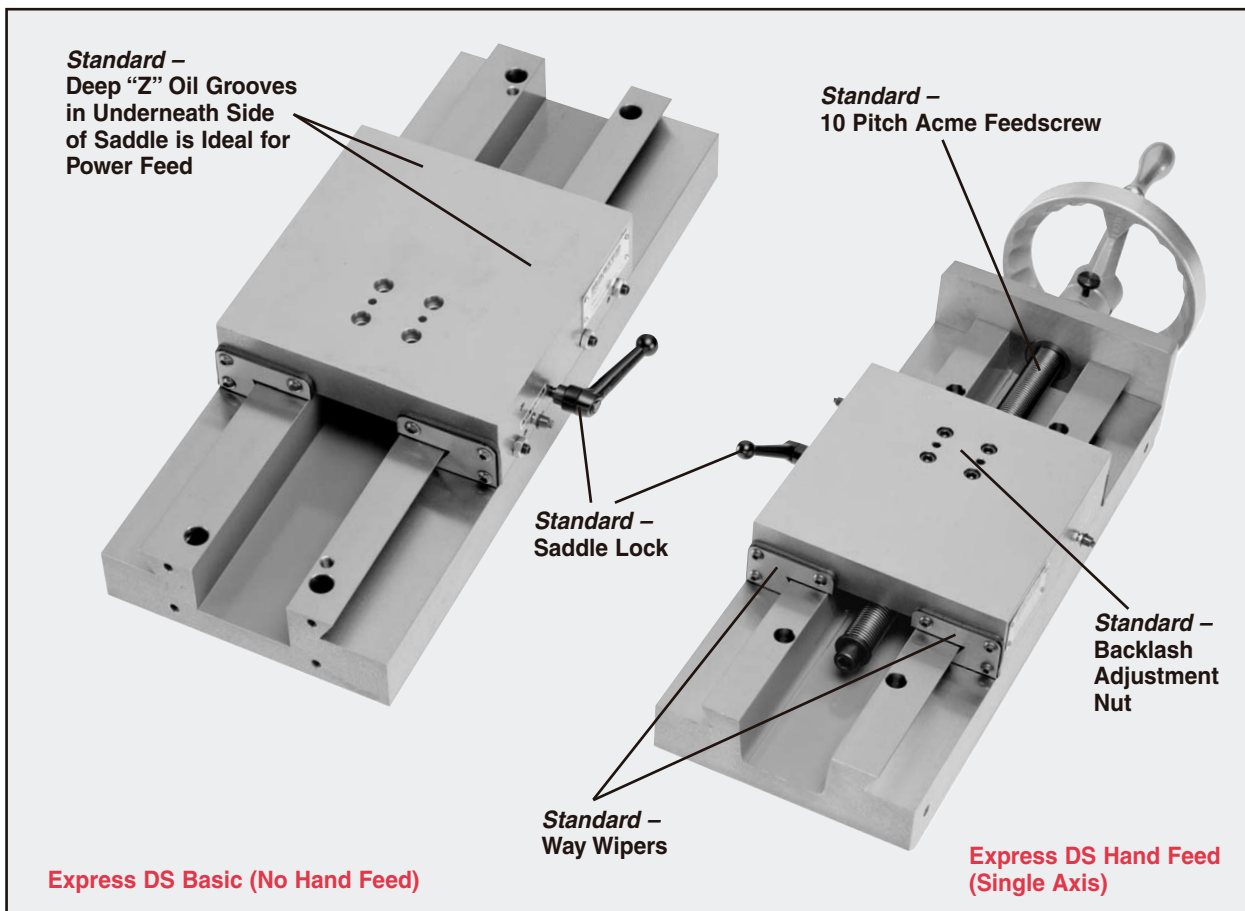

At-A-Glance, Standard Features

- One Week Shipment
- 100% Computer Designed Using 3D Modeling
- Five Pre-engineered Base Widths: 4", 6", 8", 10" or 12"
- Pre-engineered Base and Saddle Lengths
- Precision Ground Top, Bottom and Way Bearing Surfaces
- Cast Iron Base and Saddle
- Way Wipers
- Deep “Z” Oil Grooves
- Manual Lube Ports
- Steel Adjustment Gib
- Saddle Lock
- Gib Adjustment Screws
- Base Mounting Holes
- Drive Mounting Holes
- Product Lifting Holes
- Product Service and Parts Manual

How To Order

Express & Select Model Code

HOW TO ORDER SLIDE

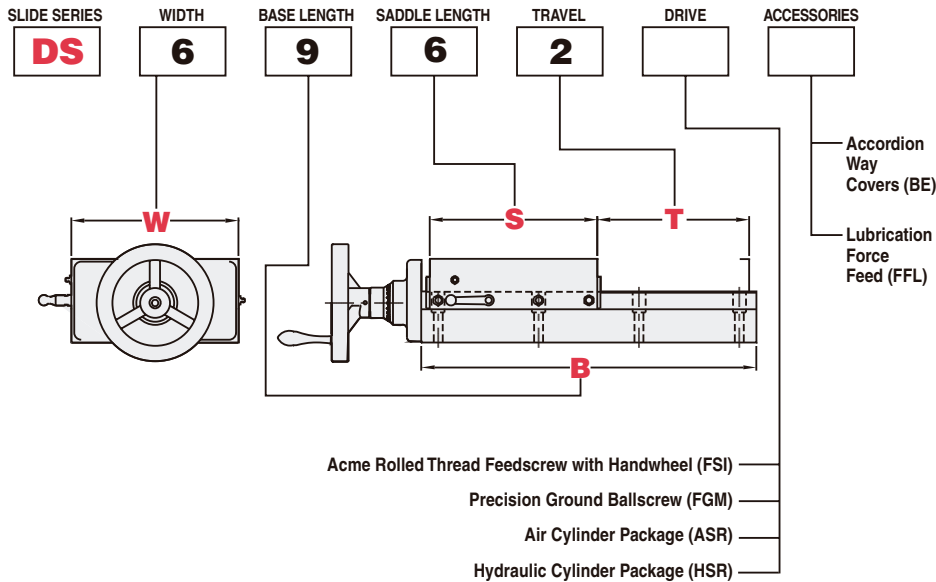

Easy Steps To DS Slide Selection

Express

1. Choose slide width (inches).
2. Choose saddle length (inches).
3. Choose slide travel (inches).
4. Choose Basic or Hand Feed.

Select

1. Choose slide width (inches).
2. Choose saddle length (inches).
3. Choose slide travel (inches).
4. Choose Drive and Accessories.

- Base Length equals the sum of steps 2 and 3 plus 1 inch for Basic, Hand Feed and Ballscrew models, and 2 inches for Cylinder Drives.
- To determine Base length when Accordion Way Covers are chosen, see page 13.

To Place Your Order

Phone: 1-800-543-0470 Fax: 1-513-941-6913
Email: sales@setcousa.com

INDEX

Page

Express

DS

Slide Width

4"	6
6"	7
8"	8
10"	9
12"	10

Select

DS

4", 6", 8", 10", 12", 16"	11
Accessories	14-16

Super Select

DS

Features & Accessories	17-19 & 42
Application Photos	21-22

BASIC (No Feed Mechanism)

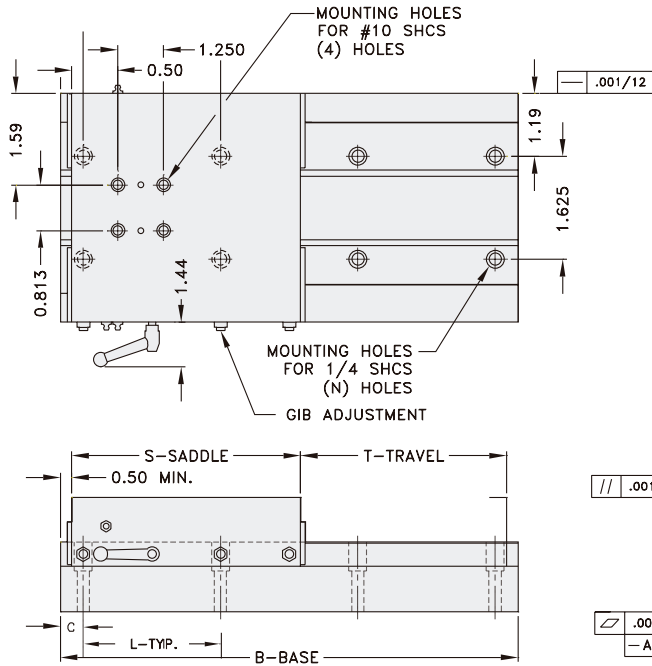

At-A-Glance, Standard Features for Basic and Hand Feed Models

- One Week Shipment
- 100% Computer Designed
- Pre-engineered Base and Saddle Lengths
- -20" Maximum Base
- -6" Maximum Saddle
- Precision Ground Top, Bottom and Way Bearing Surfaces
- Cast Iron Base and Saddle
- Way Wipers
- Deep "Z" Oil Grooves
- Manual Lube Ports
- Steel Adjustment Gib
- Saddle Lock
- Gib Adjustment Screws
- Base Mounting Holes
- Drive Mounting Holes
- Product Lifting Holes
- Product Service and Parts Manual

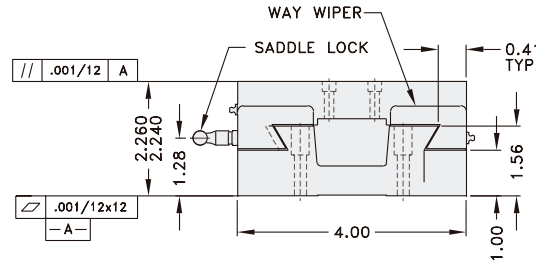

HAND FEED (Single Axis)

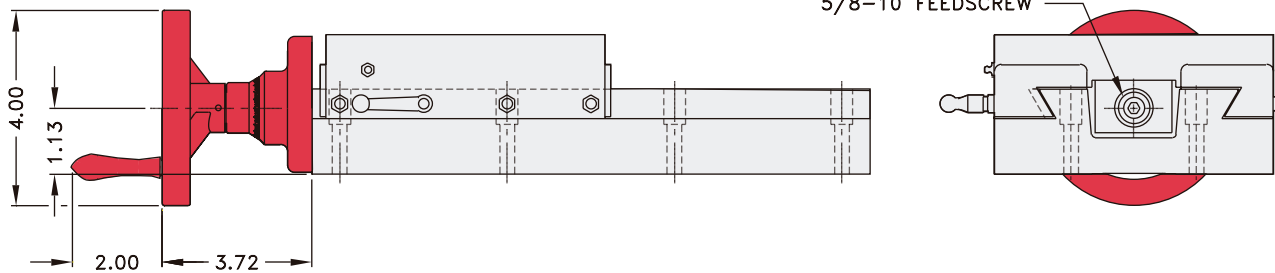

MODEL		DIMENSIONS IN INCHES						WEIGHT (Lb.)	
Basic	Hand Feed	B - Base	S - Saddle	T - Travel	C	L	N	Basic	FSI
DS4-8-4-3-B	DS4-8-4-3-FSI	8.00	4.00	3.00	1.000	3.00	6	12.5	17.1
DS4-8-6-1-B	DS4-8-6-1-FSI	8.00	6.00	1.00	1.000	3.00	6	14.1	18.7
DS4-12-4-7-B	DS4-12-4-7-FSI	12.00	4.00	7.00	1.500	3.00	8	16.9	22.0
DS4-12-6-5-B	DS4-12-6-5-FSI	12.00	6.00	5.00	1.500	3.00	8	18.6	23.5
DS4-16-4-11-B	DS4-16-4-11-FSI	16.00	4.00	11.00	2.000	6.00	6	21.5	27.0
DS4-16-6-9-B	DS4-16-6-9-FSI	16.00	6.00	9.00	2.000	6.00	6	23.2	28.5
DS4-20-4-15-B	DS4-20-4-15-FSI	20.00	4.00	15.00	1.000	6.00	8	26.0	31.8
DS4-20-6-13-B	DS4-20-6-13-FSI	20.00	6.00	13.00	1.000	6.00	8	27.7	33.3

BASIC (No Feed Mechanism)

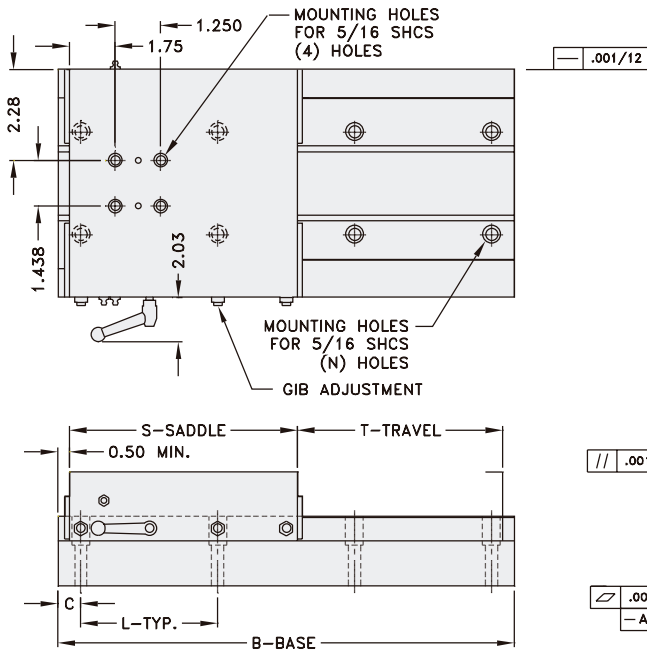

At-A-Glance, Standard Features for Basic and Hand Feed Models

- One Week Shipment
- 100% Computer Designed
- Pre-engineered Base and Saddle Lengths
 - 18" Maximum Base
 - 9" Maximum Saddle
- Precision Ground Top, Bottom and Way Bearing Surfaces
- Cast Iron Base and Saddle
- Way Wipers
- Deep "Z" Oil Grooves
- Manual Lube Ports
- Steel Adjustment Gib
- Saddle Lock
- Gib Adjustment Screws
- Base Mounting Holes
- Drive Mounting Holes
- Product Lifting Holes
- Product Service and Parts Manual

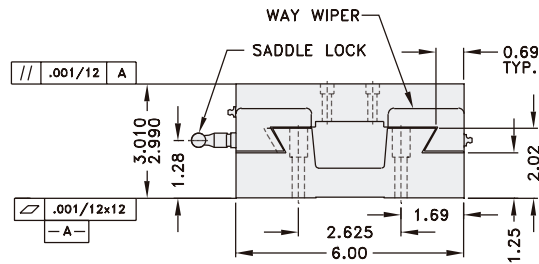

HAND FEED (Single Axis)

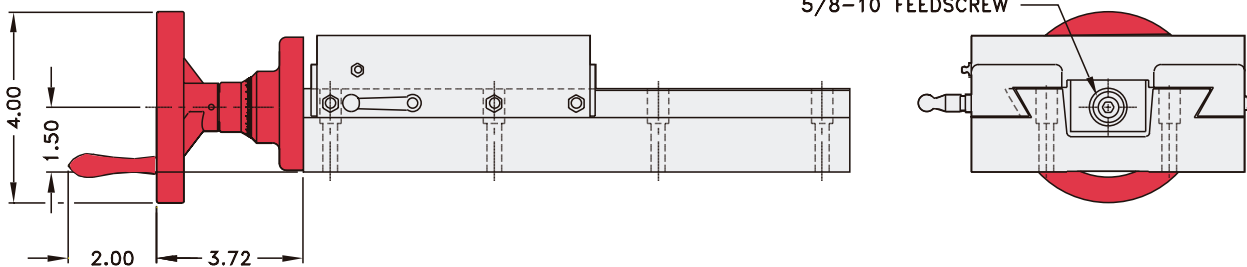

MODEL		DIMENSIONS IN INCHES							WEIGHT (Lb.)	
Basic	Hand Feed	B - Base	S - Saddle	T - Travel	C	L	N	Basic	FSI	
DS6-9-6-2-B	DS6-9-6-2-FSI	9.00	6.00	2.00	1.500	3.00	6	28.4	37.6	
DS6-12-6-5-B	DS6-12-6-5-FSI	12.00	6.00	5.00	1.500	3.00	8	34.3	43.8	
DS6-12-9-2-B	DS6-12-9-2-FSI	12.00	9.00	2.00	1.500	3.00	8	39.6	48.8	
DS6-15-6-8-B	DS6-15-6-8-FSI	15.00	6.00	8.00	1.500	6.00	6	40.2	50.0	
DS6-15-9-5-B	DS6-15-9-5-FSI	15.00	9.00	5.00	1.500	6.00	6	45.5	54.9	
DS6-18-6-11-B	DS6-18-6-11-FSI	18.00	6.00	11.00	3.000	6.00	6	46.6	56.6	
DS6-18-9-8-B	DS6-18-9-8-FSI	18.00	9.00	8.00	3.000	6.00	6	51.8	61.6	

BASIC (No Feed Mechanism)

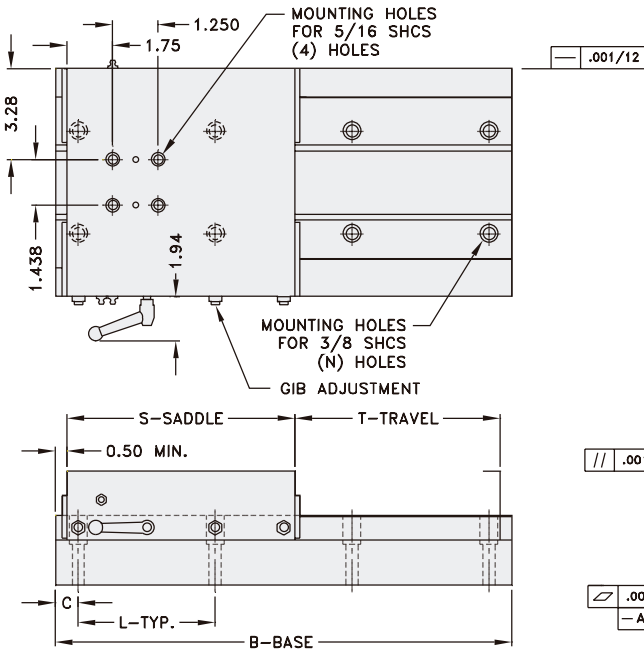

At-A-Glance, Standard Features for Basic and Hand Feed Models

- One Week Shipment
- 100% Computer Designed
- Pre-engineered Base and Saddle Lengths
- -20" Maximum Base
- -12" Maximum Saddle
- Precision Ground Top, Bottom and Way Bearing Surfaces
- Cast Iron Base and Saddle
- Way Wipers
- Deep "Z" Oil Grooves
- Manual Lube Ports
- Steel Adjustment Gib
- Saddle Lock
- Gib Adjustment Screws
- Base Mounting Holes
- Drive Mounting Holes
- Product Lifting Holes
- Product Service and Parts Manual

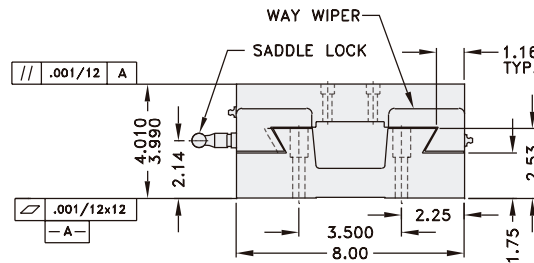

HAND FEED (Single Axis)

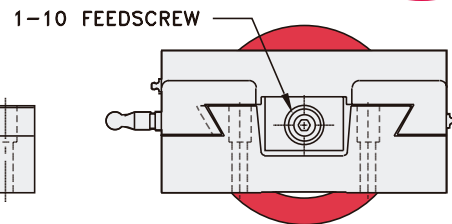
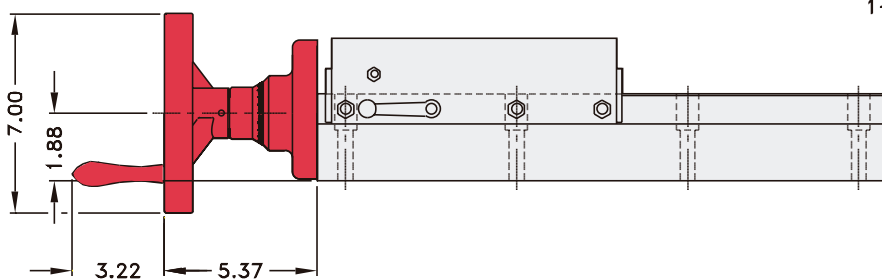

MODEL		DIMENSIONS IN INCHES						WEIGHT (Lb.)	
Basic	Hand Feed	B - Base	S - Saddle	T - Travel	C	L	N	Basic	FSI
DS8-12-8-3-B	DS8-12-8-3-FSI	12.00	8.00	3.00	1.500	3.00	8	69.5	85.7
DS8-16-8-7-B	DS8-16-8-7-FSI	16.00	8.00	7.00	2.000	6.00	6	83.9	101.0
DS8-16-12-3-B	DS8-16-12-3-FSI	16.00	12.00	3.00	2.000	6.00	6	97.8	114.0
DS8-20-8-11-B	DS8-20-8-11-FSI	20.00	8.00	11.00	1.000	6.00	8	97.8	115.8
DS8-20-12-7-B	DS8-20-12-7-FSI	20.00	12.00	7.00	1.000	6.00	8	111.7	128.8

BASIC (No Feed Mechanism)

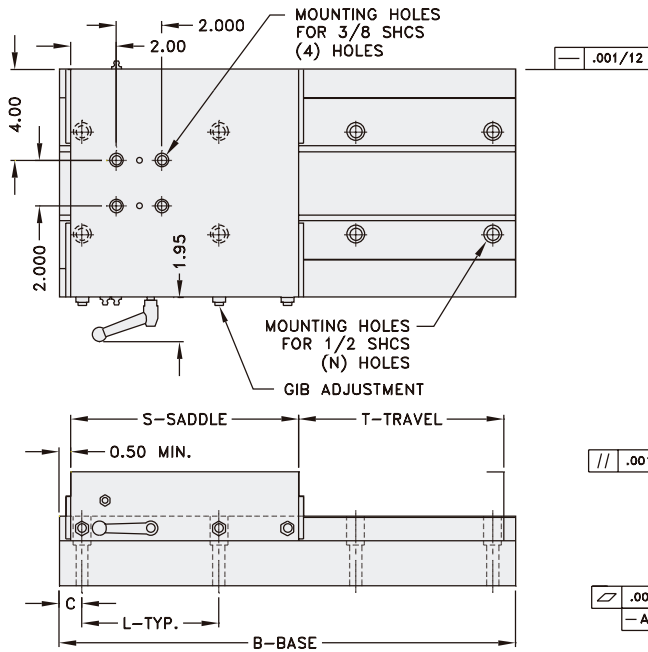

At-A-Glance, Standard Features for Basic and Hand Feed Models

- One Week Shipment
- 100% Computer Designed
- Pre-engineered Base and Saddle Lengths
- -20" Maximum Base
- -10" Saddle
- Precision Ground Top, Bottom and Way Bearing Surfaces
- Cast Iron Base and Saddle
- Way Wipers
- Deep "Z" Oil Grooves
- Manual Lube Ports
- Steel Adjustment Gib
- Saddle Lock
- Gib Adjustment Screws
- Base Mounting Holes
- Drive Mounting Holes
- Product Lifting Holes
- Product Service and Parts Manual

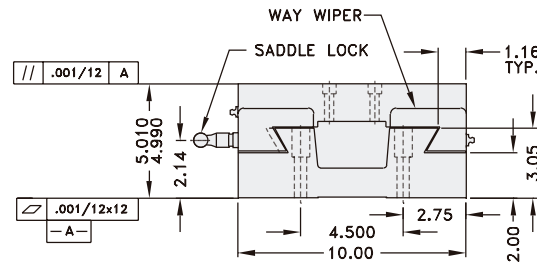

HAND FEED (Single Axis)

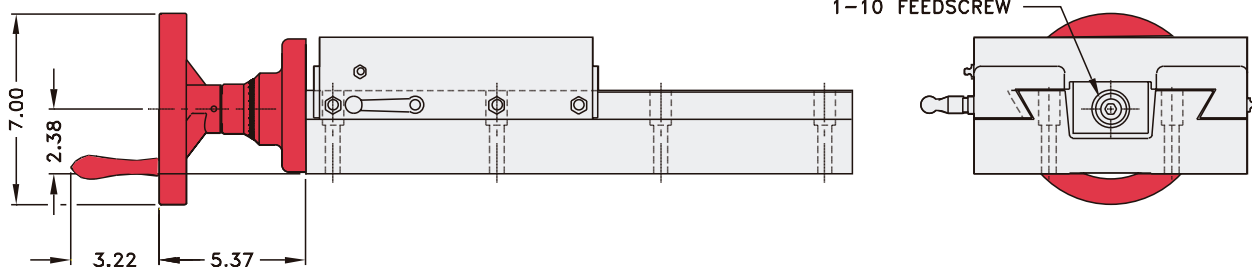

MODEL		DIMENSIONS IN INCHES						WEIGHT (Lb.)	
Basic	Hand Feed	B-Base	S-Saddle	T-Travel	C	L	N	Basic	FSI
DS10-15-10-4-B	DS10-15-10-4-FSI	15.00	10.00	4.00	1.500	6.00	6	137.5	160.0
DS10-20-10-9-B	DS10-20-10-9-FSI	20.00	10.00	9.00	1.000	6.00	8	165.7	189.0

BASIC (No Feed Mechanism)

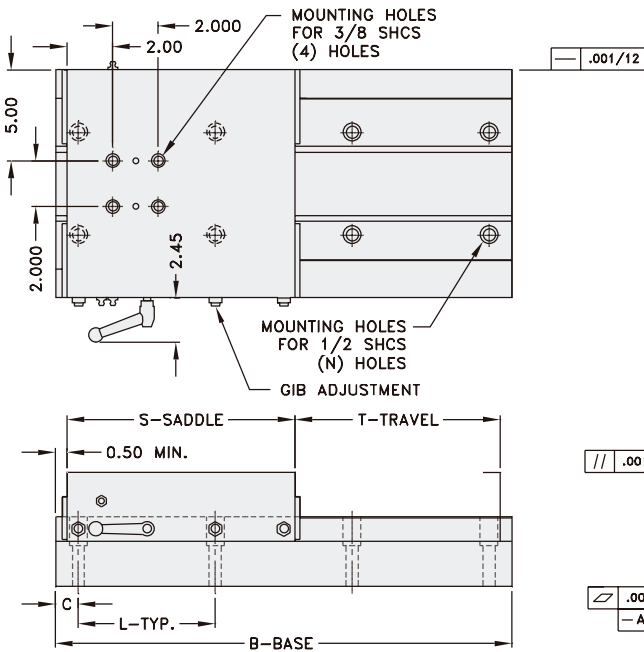

At-A-Glance, Standard Features for Basic and Hand Feed Models

- One Week Shipment
- 100% Computer Designed
- Pre-engineered Base and Saddle Lengths
- -24" Base
- -12" Saddle
- Precision Ground Top, Bottom and Way Bearing Surfaces
- Cast Iron Base and Saddle
- Way Wipers
- Deep "Z" Oil Grooves
- Manual Lube Ports
- Steel Adjustment Gib
- Saddle Lock
- Gib Adjustment Screws
- Base Mounting Holes
- Drive Mounting Holes
- Product Lifting Holes
- Product Service and Parts Manual

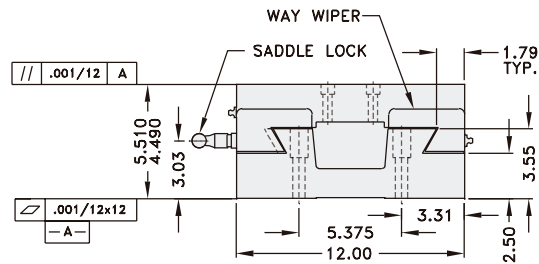

HAND FEED (Single Axis)

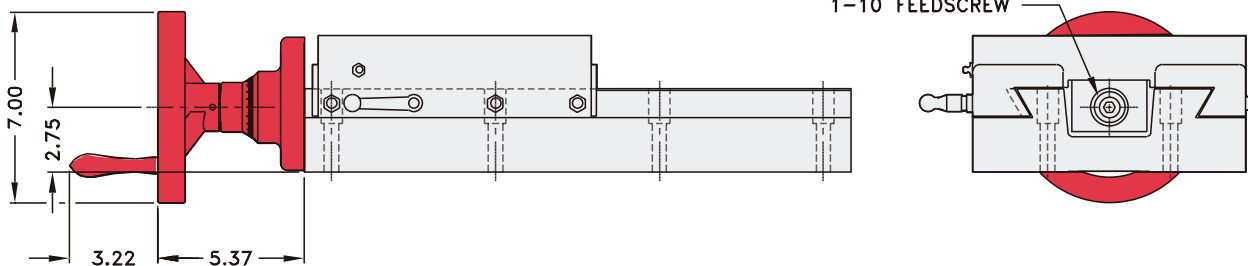

MODEL		DIMENSIONS IN INCHES						WEIGHT (Lb.)	
Basic	Hand Feed	B-Base	S-Saddle	T-Travel	C	L	N	Basic	FSI
DS12-24-12-11-B	DS12-24-12-11-FSI	24.00	12.00	11.00	3.000	6.00	8	171	300

Select DS

- Six Pre-engineered Base Widths: 4", 6", 8", 10", 12" or 16"
- Base Lengths Available in 1" Increments Up to 64"
- Saddle Lengths Available in 1" Increments Up to 64"

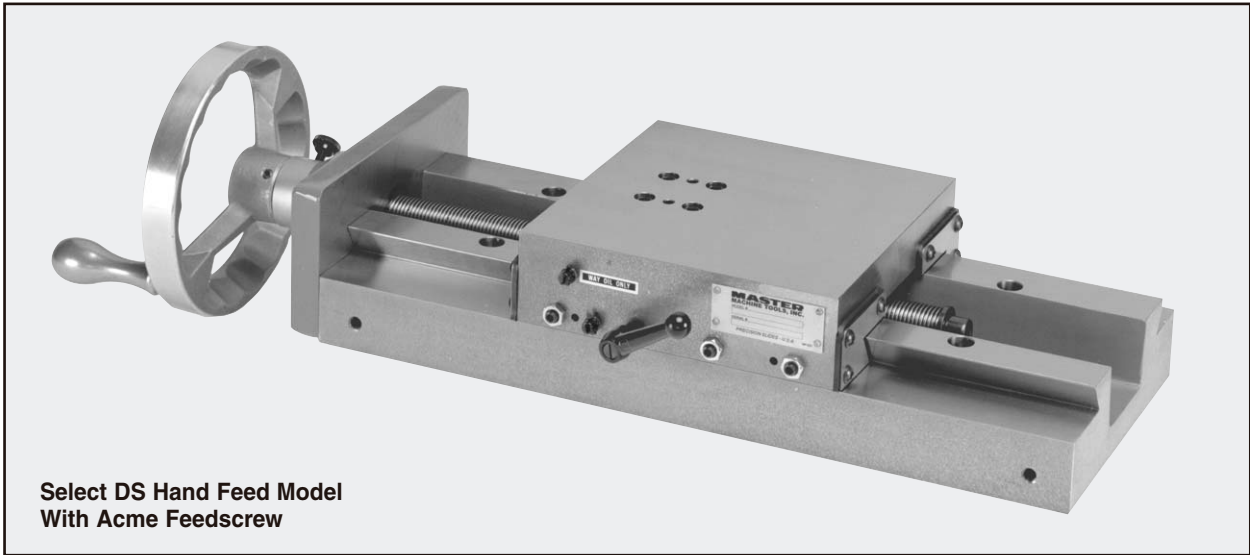

At-A-Glance, Standard Features

- Three Week Shipment
- 100% Computer Designed Using 3D Modeling
- Six Pre-engineered Base Widths: 4", 6", 8", 10", 12" or 16"
- Base Lengths in 1" Increments Up to 64" Maximum
- Saddle Lengths in 1" Increments Up to 64" Maximum
- Precision Ground Top, Bottom and Way Bearing Surfaces
- Cast Iron Base and Saddle
- Way Wipers
- Deep "Z" Oil Grooves
- Manual Lube Ports
- Full-Length Steel Adjustment Gib
- Saddle Lock
- Gib Adjustment Screws
- Base Mounting Holes
- Drive Mounting Holes
- Product Lifting Holes
- Product Service and Parts Manual

Additional Standard Features for Hand Feed Models Only

- Handwheel and Micrometer Dial
- Feedscrew Drive with Rolled Acme Thread
 - 0.625" Diameter Screw for 4" and 6" Slides
 - 1.000" Diameter Screw for 8", 10", and 12" Slides
 - 1.500" Diameter Screw for 16" Slides
- Feedscrew Thread Backlash Adjustment

At-A-Glance Options

- Force Feed Lubrication
- Accordion Way Covers

At-A-Glance Drive Options

- Air Cylinder Drive
- Hydraulic Cylinder Drive
- *Ballscrew Drive** (Shipment: Five Weeks)

* NOT AVAILABLE ON 4" SELECT DS SLIDE

Select DS 4", 6", 8", 10", 12" or 16"

BASIC (No Feed Mechanism)

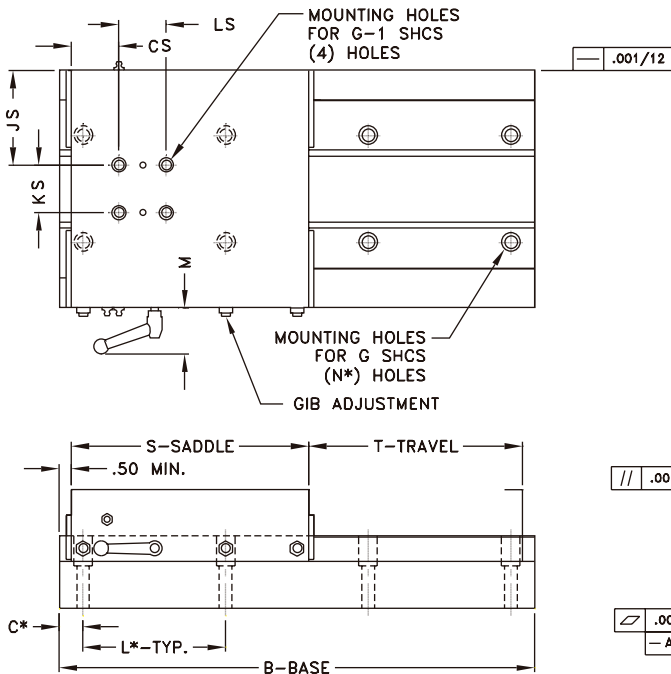

	WT. PER INCH*	
	Base LBS/IN	Saddle LBS/IN
DS4	1.12	0.80
DS6	2.00	1.68
DS8	3.50	3.38
DS10	5.44	5.50
DS12	7.75	6.94
DS16	12.00	10.88

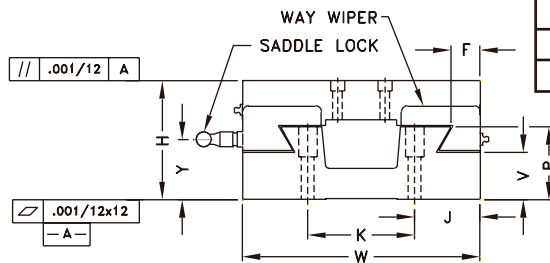

*Semi-finished dimension weight.



HAND FEED (Single Axis)

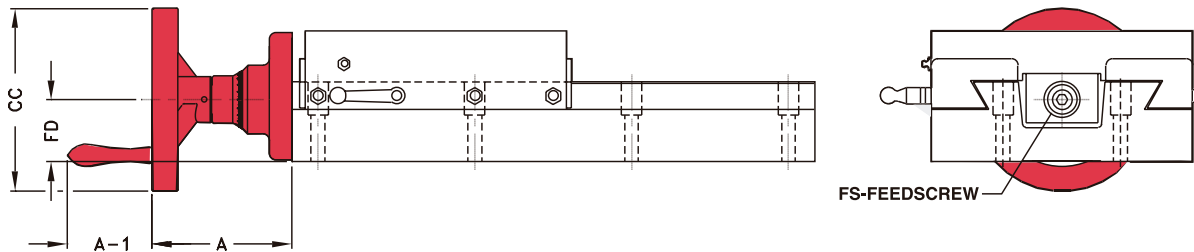

MODEL		DIMENSIONS IN INCHES										
Basic	Hand Feed	B-Base	S-Saddle	T-Travel	Saddle Min.	Y	W	V	P	H	JS	
DS4□□□B	DS4□□□FSI	1"-Incr	1"-Incr	1"-Incr	4.00	1.3	4.00	1.00	1.56	2.25	1.59	
DS6□□□B	DS6□□□FSI	1"-Incr	1"-Incr	1"-Incr	6.00	1.6	6.00	1.25	2.02	3.00	2.28	
DS8□□□B	DS8□□□FSI	1"-Incr	1"-Incr	1"-Incr	8.00	2.1	8.00	1.75	2.53	4.00	3.28	
DS10□□□B	DS10□□□FSI	1"-Incr	1"-Incr	1"-Incr	10.00	2.5	10.00	2.00	3.05	5.00	4.00	
DS12□□□B	DS12□□□FSI	1"-Incr	1"-Incr	1"-Incr	12.00	3.0	12.00	2.50	3.55	5.50	5.00	
DS16□□□B	DS16□□□FSI	1"-Incr	1"-Incr	1"-Incr	16.00	3.5	16.00	2.75	4.30	6.50	6.50	

MODEL	DIMENSIONS IN INCHES														MAX. TRAVEL W/O OUTBOARD SUPPORT
	KS	CS	LS	J	K	M	G	G-1	F	A	A-1	FD	CC	FS	
DS4□□□B	0.813	0.50	1.250	1.19	1.625	1.44	1/4	#10	0.41	3.72	2.00	1.13	4.00	5/8-10	16.00
DS6□□□B	1.438	1.75	1.250	1.69	2.625	2.03	5/16	5/16	0.69	3.72	2.00	1.50	4.00	5/8-10	16.00
DS8□□□B	1.438	1.75	1.250	2.25	3.500	1.94	3/8	5/16	1.16	5.37	3.22	1.88	7.00	1-10	24.00
DS10□□□B	2.000	2.00	2.000	2.75	4.500	1.95	1/2	3/8	1.16	5.37	3.22	2.38	7.00	1-10	24.00
DS12□□□B	2.000	2.00	2.000	3.31	5.375	2.45	1/2	3/8	1.79	5.37	3.22	2.75	7.00	1-10	24.00
DS16□□□B	3.000	2.50	2.50	4.50	7.000	2.86	5/8	3/8	2.32	6.81	3.44	3.13	10.00	1.5-10	30.00

$N^* = \text{Floor}[(B - 2) + L] + 1 \times 2$
 $L^* = 3$ if $B < 15$ or else $L^* = 6$
 $C^* = [B - (L^* \cdot \frac{N^* - 1}{2})] + 2$

Floor = round down to the nearest integer

Select DS

Accessories

ACCORDION WAY COVERS*

(Model Code: BE)

The Accordion Way Cover accessory is designed to shield slide way surfaces, feed mechanisms and slide cavity from contamination by abrasive material, coolant and dust. Made of polyurethane coated nylon, these protective covers are available for Select DS and Super Select DS slides.

Note: When Accordion Way Covers are used, the slide travel length is reduced due to the stack-up of accordion bellow folds at each end of the slide. As shown in the illustration for the Select DS Series (below), the Accordion Way Cover will extend beyond the sides (OW dimension) — and above the top of the saddle on 4" and 6" slides. Because the base and saddle lengths of Select DS Series slides are available in one inch increments, the actual base length when the Accordion Way Cover accessory is chosen will vary accordingly.

To determine this actual travel (or base length), use the following formula:

$$B = (T \times MU) + 2 + S$$

Where: B = Base length

S = Saddle length

T = Travel

MU = From adjacent chart

To determine stack-up of the accordion way cover folds at each end of the slide, use the CL formula from the adjacent chart.

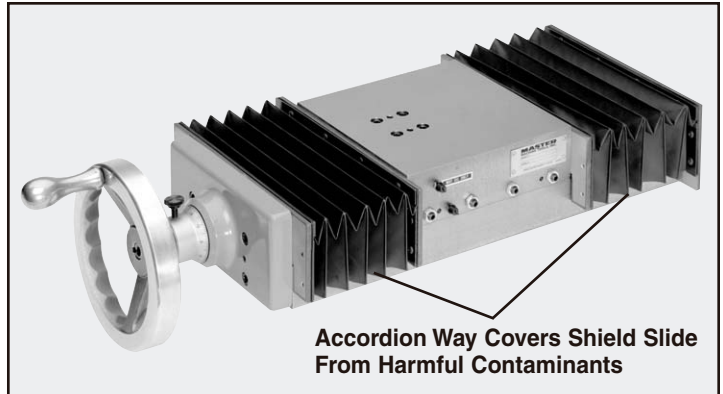

Accordion Way Covers Shield Slide From Harmful Contaminants

MODEL NUMBER CODE

DS 6 - 13 - 9 - 2 - BE

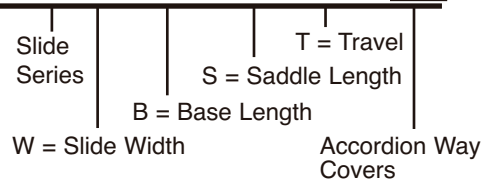

MODEL	CL	H	MU	OW	U	W
DS4	CL = B - S - T 2	2.63	1.41	5.65	0.83	4.00
DS6		3.25	1.41	7.65	0.83	6.00
DS8		3.88	1.27	10.13	1.06	8.00
DS10		4.56	1.27	12.13	1.06	10.00
DS12		4.93	1.27	14.13	1.06	12.00
DS16		5.81	1.27	18.13	1.06	16.00

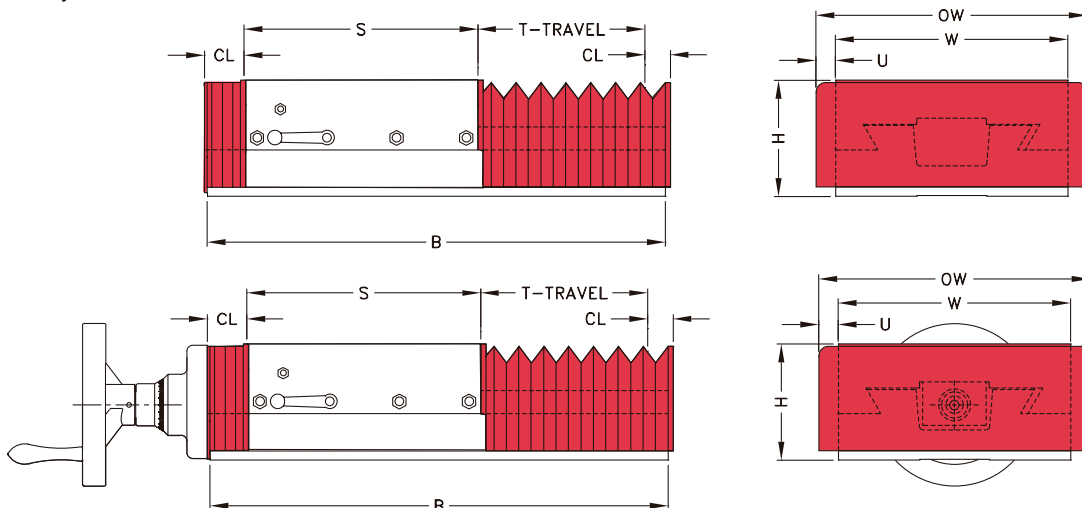

*Consult SETCO Solution Team for special covers when contaminants are sharp or heavy in nature.

PRECISION GROUND THREAD BALLSCREW*

(Model Code: FGM)

A Precision Ground Thread Ballscrew package with integral preloaded single ballnut is recommended for applications where:

- Optimum positioning accuracy and repeatability are required.
- Backlash cannot be tolerated.
- Optimum stiffness and smooth, linear motion are required.

The lead accuracy of the precision ballscrew is within 0.0005 in./ft. cumulative, with the integral preloaded single ballnut providing zero backlash. The ballscrew is supported by a taper roller thrust bearing.

To protect the ballscrew from contaminants, optional accordion protectors are recommended.

Applications requiring long travels or high traverse rates may require an optional outboard support mounted on the end opposite the drive.

- Notes:** 1. For force and torque requirements, see page 49.
2. For optional drive packages, see pages 20 and 21.

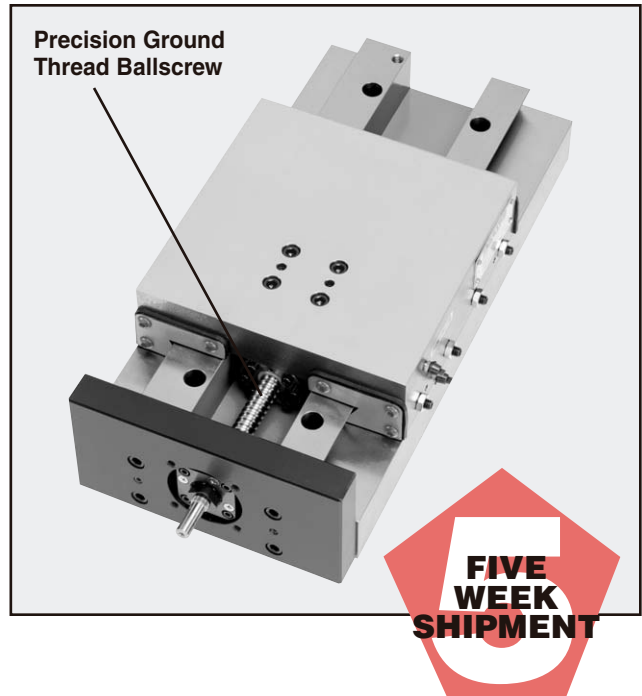

MODEL NUMBER CODE

DS 6 - 9 - 6 - 2 - FGM

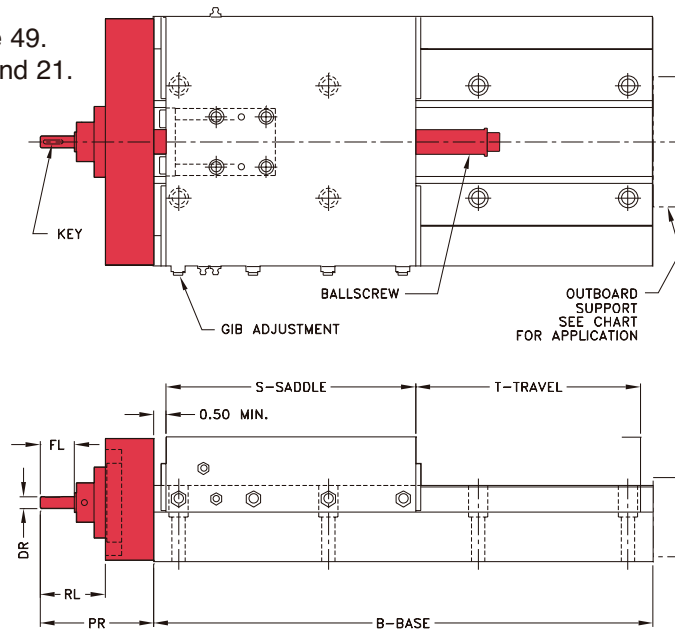
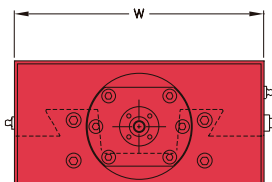
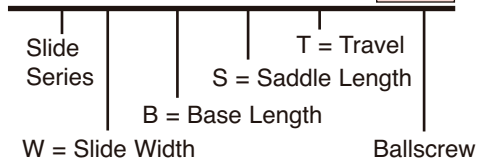

MODEL	METRIC	DIMENSIONS IN INCHES				METRIC		MAX. TRAVEL W/O OUTBOARD SUPPORT
		Basic	DR	FL	RL	PR	Key	
DS4□□□FGM	N/A	N/A	N/A	N/A	N/A	N/A	N/A	N/A
DS6□□□FGM	10MM	0.98	1.34	2.34	3MM X 16MM	16MM X 5MM RH	16.0	
DS8□□□FGM	10MM	0.98	1.34	2.34	3MM X 16MM	16MM X 5MM RH	16.0	
DS10□□□FGM	12MM	1.38	2.61	4.55	4MM X 16MM	25MM X 5MM RH	24.0	
DS12□□□FGM	12MM	1.38	2.61	4.55	4MM X 16MM	25MM X 5MM RH	24.0	
DS16□□□FGM	25MM	1.57	3.01	5.07	8MM X 25MM	40MM X 10MM RH	30.0	

*Covers are recommended for applications that involve contaminants. Consult the SETCO Solution Team for further assistance.

AIR OR HYDRAULIC CYLINDER DRIVES

(Air Cylinder Model Code: ASR)
(Hydraulic Cylinder Model Code: HSR)

The Air Cylinder Drive accessory is designed with a 200 psi endurance rating and a cushioned cap end. This type of DS slide offers an economical and virtually maintenance-free system. It operates on dry, clean shop air, and is commonly used for light applications that do not require fine control of feedrate, or multiple position applications.

The Hydraulic Cylinder Drive accessory is designed with a 500 psi endurance rating and a cushioned cap end. This type of DS slide is used for heavier load applications that require fine feed control or multiple feeding.

Included as standard with either the Air or Hydraulic Cylinder accessory packages is an adjustable positive stop mounted alongside the cylinder. Way wipers are also included.

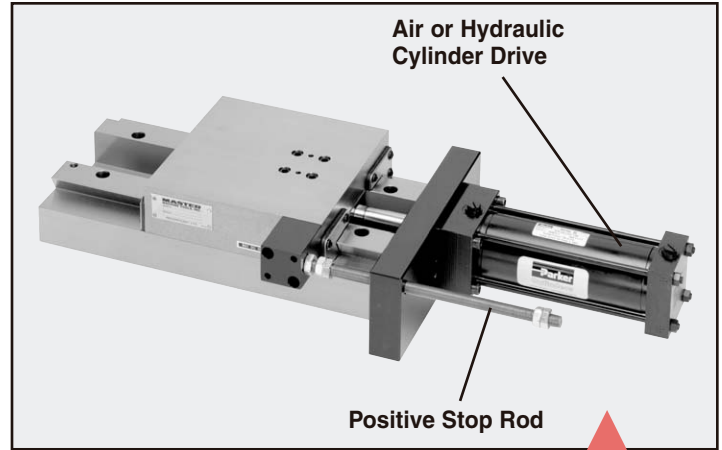

MODEL NUMBER CODE

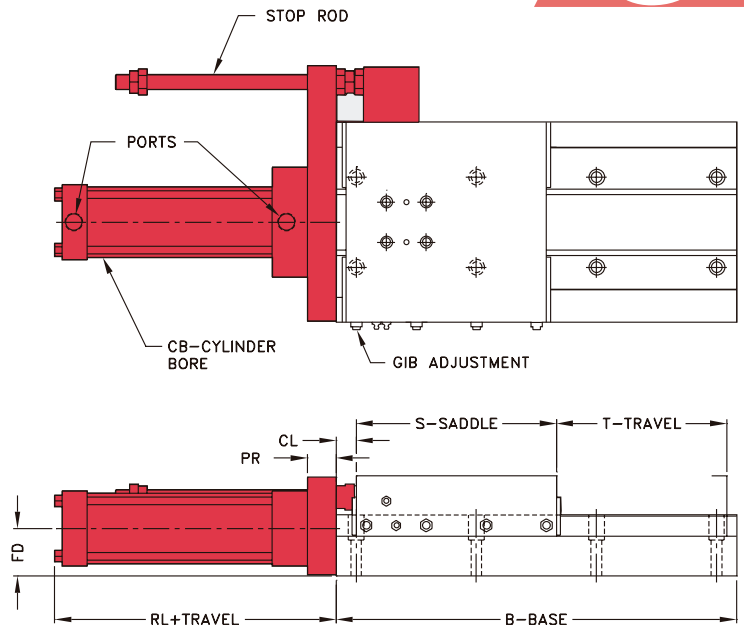
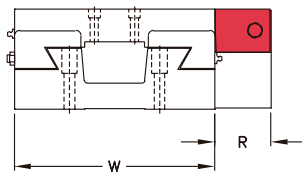
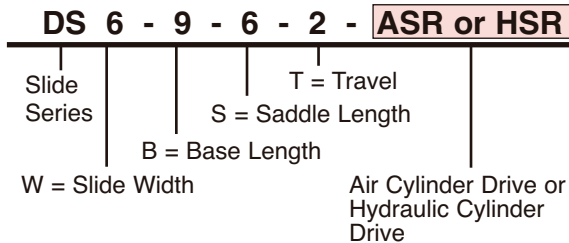

DIMENSIONS IN INCHES								
MODEL	W	R	CL	CB	FD	PR	RL	STOP ROD
DS4□□□HSR	4.00	1.56	1.00	1.50	1.13	1.13	4.25	0.375
DS6□□□HSR	6.00	2.06	1.00	2.00	1.69	1.25	3.93	0.50
DS8□□□HSR	8.00	2.25	1.00	2.50	2.06	1.38	4.06	0.50
DS10□□□HSR	10.00	2.81	1.00	3.25	2.38	1.44	4.63	0.75
DS12□□□HSR	12.00	3.06	1.00	4.00	2.75	1.63	4.63	0.75
DS16□□□HSR	16.00	3.56	1.00	5.00	3.13	1.75	4.94	1.00

Select DS

Accessories

FORCE FEED LUBRICATION

(Model Code: FFL)

The One Shot Force Feed Lubrication System is recommended when closely controlled, but infrequent, oil feed is required. This simple, economical system can be mounted to the slide assembly and includes a one pint reservoir, junction header, metering units, plus all piping and connections.

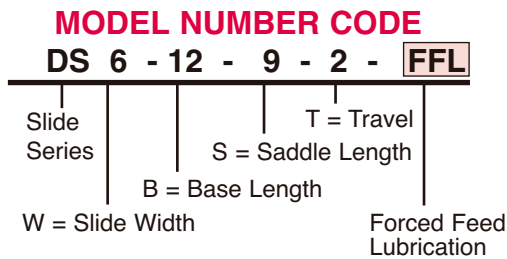
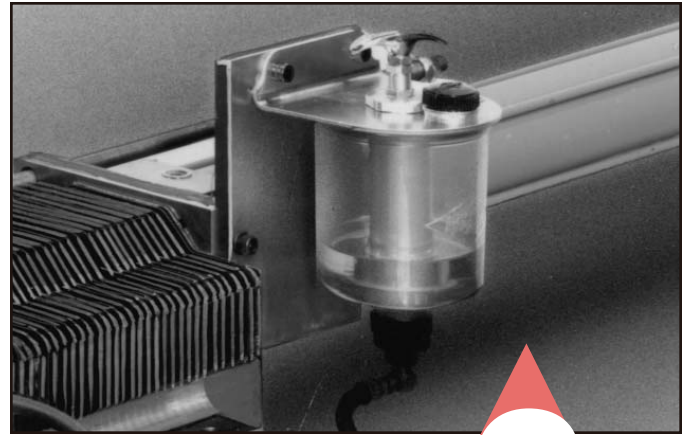

STANDARD DEEP "Z" OIL GROOVE DESIGN FOR EXPRESS, SELECT & SUPER SELECT

DS Series and M Series slides (page 30) are standard with porting and oil grooving for acceptance of an automatic or manual lubrication system.

- Drawing 'A' shows Master's Standard Z Oil Grooves machined into the underneath side of the dovetail saddle.
- Drawing 'B' shows the standard internal porting to the slide ways, gib and optional nut.
- Mobil Vactra #2 Way Oil (or an equivalent) is recommended for automatic and manual lubrication systems.

Standard - Deep "Z" Oil Grooves

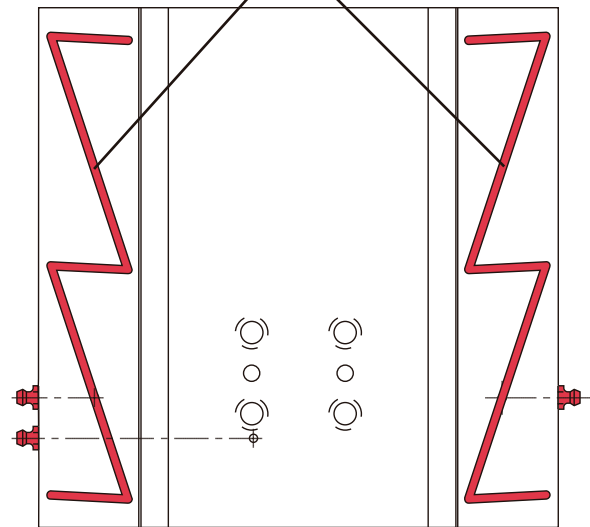

DRAWING A

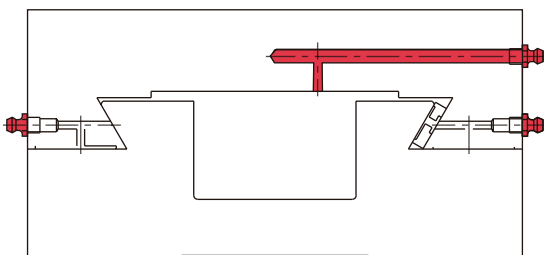

DRAWING B

	Lube Part Size
DS4	1/4 - 28
DS6	1/4 - 28
DS8	1/4 - 28
DS10	1/8 - 27NPT
DS12	1/8 - 27NPT
DS16	1/8 - 27NPT

Super Select DS

**Slides for Every
Application**

- **Six Base Widths: 4", 6", 8", 10", 12" or 16"**
- **Base Lengths Available Up to 96"**
- **Saddle Lengths Available Up to 96"**

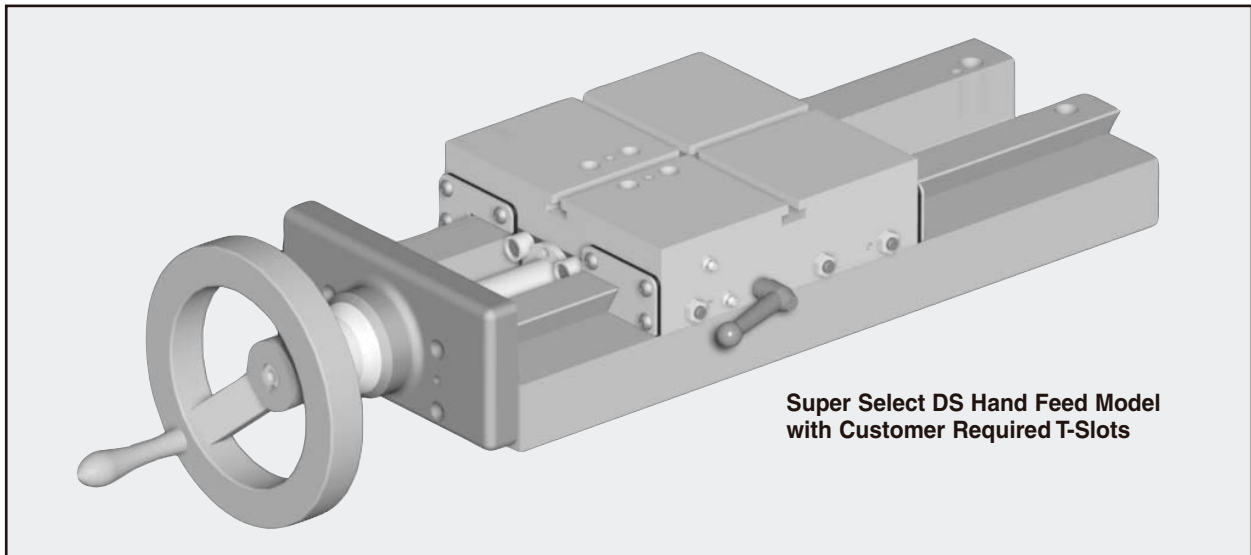

Super Select DS Hand Feed Model
with Customer Required T-Slots

At-A-Glance, Super Select DS

- 100% Computer Designed Using 3D Modeling
- Slides Engineered Around Standard Baseline Product
- Slides Easily Modified to Meet Your Application Requirements
- Custom Slide Solutions Reduce Leadtimes and Cost Premiums
- One-Source Technical Slide Help from SETCO Solution Engineers
- Full Line of Commercial Slide Accessories Available
- Six Base Widths: 4", 6", 8", 10", 12" or 16"
- Base Lengths in Up to 96"
- Saddle Lengths Up to 96"
- Stress Relieved Cast Iron Base and Saddle
- Deep "Z" Oil Grooves
- Product Lifting Holes
- Product Service and Parts Manual

Super Select Model Code

HOW TO ORDER SLIDE

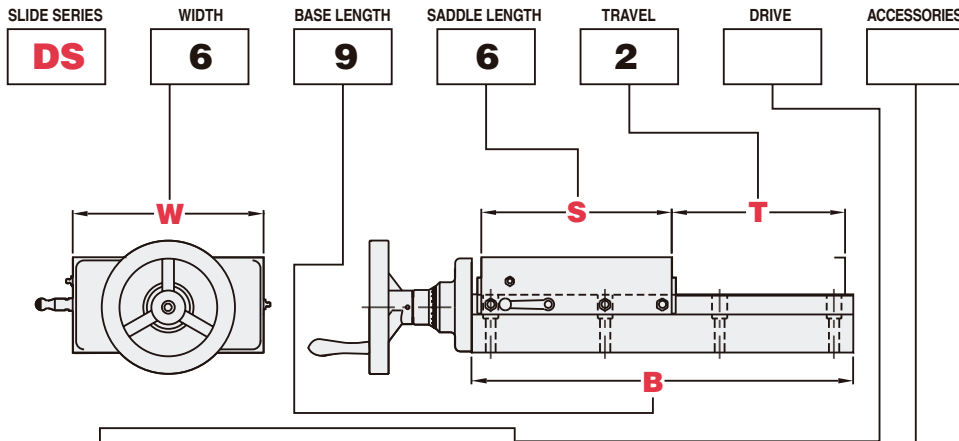

- No Drive (B)
- Acme Rolled Thread Feedscrew with Handwheel (FSI)
- Right Angle Hand Feed (RAF)
- Ratchet Handle Hand Feed (RH)
- Precision Ground Ballscrew (FGM)
- Belt Drive Package (U)
- Direct Coupled Drive Package (M)
- Air Cylinder Packages (ASR)
- Hydraulic Cylinder Packages (HSR)
- ☒ Servo Cylinder Drive
- ☒ Air/Oil Tandem Feed and Rapid Cycle
- ☒ Air Cylinder with Controlled Feed Cycle
- ☒ Special Ballscrew

- Accordion Way Covers (BE)
- Metal Clad Protectors (H)
- Low-Friction Material (T)
- Force Feed Lubrication (FFL)
- Automatic Lubrication (A)
- Positive Stop (Q)
- Limit Switches
 - (2) End Travel (E)
 - (3) Travel < Saddle Length (F)
 - (3) Travel > Saddle Length (G)
- Vertical Angle Plate (P)
- Tapered Gib (X)
- Drilling (D)
- Keyway (K)
- T-Slot (S)
- Special Limit Switches
- ☒ Special Tracking Tolerances
- ☒ Compound Slide

☒ Consult Factory for Special Model Code.

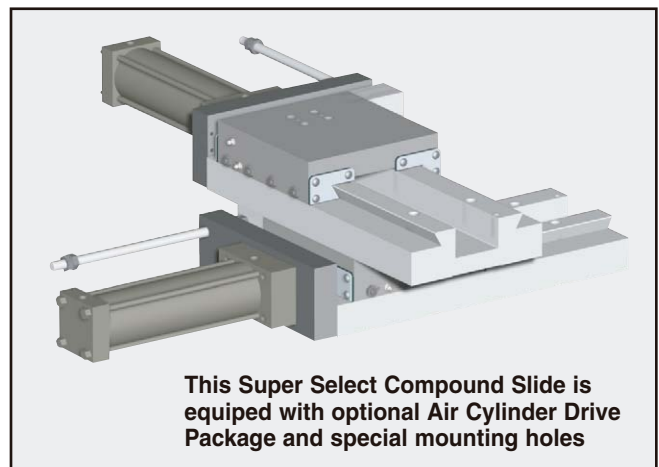
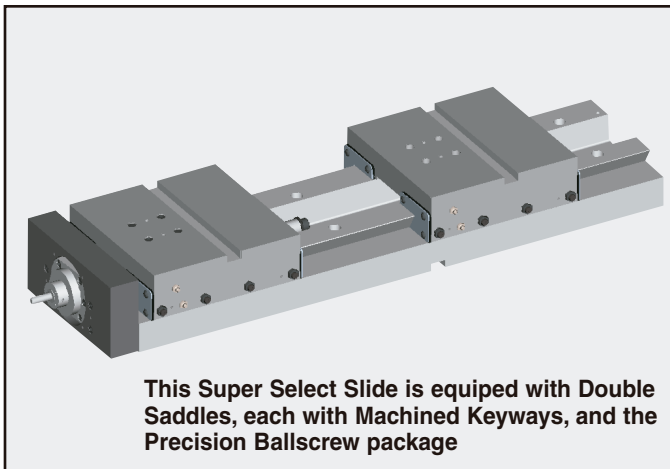

BELT DRIVE PACKAGE

(Model Code: U)

The 2:1 belt drive package is available to adapt 'C-face' mounted motors. This package allows the use of smaller, less torque, and more economical motors. The package consists of a 2:1 timing belt drive, combination motor mounting bracket/belt guard, and motor mounting plate for belt tensioning.

Submit complete specifications on the motor application to assure proper selection and sizing of the motor drive package.

Also available with other special timing belt ratios – consult factory.

Notes: 1. Requires "optional" feedscrew or ballscrew design.

2. Since motor drives will vary per application, complete dimensions of belt drive package can only be supplied at final design.

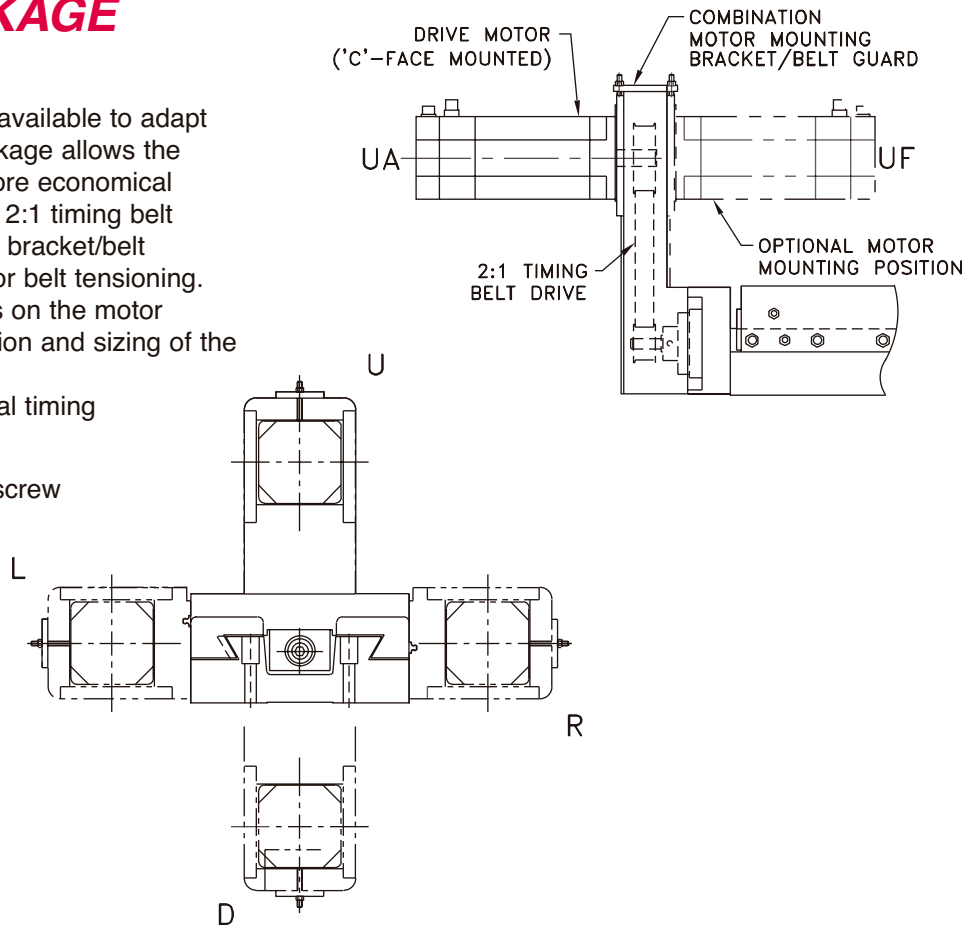

DIRECT COUPLED DRIVE PACKAGE

(Model Code: M)

The direct coupled drive package is available to adapt 'C-face' mounted or foot mounted motors. This package allows for higher traverse rates and offers compactness in design. The package consists of a 'zero' backlash coupling and motor mounting plate; and for foot mounted motors, a motor mounting bracket.

Submit complete specification on the motor application to assure proper selection and sizing of the motor drive package.

Note: Since motor drives will vary per application, complete dimensions of direct coupled package can only be supplied at final design.

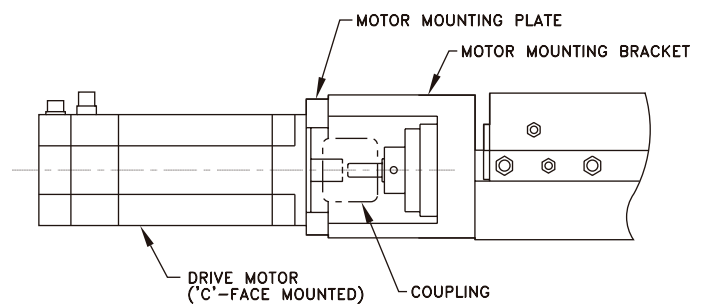
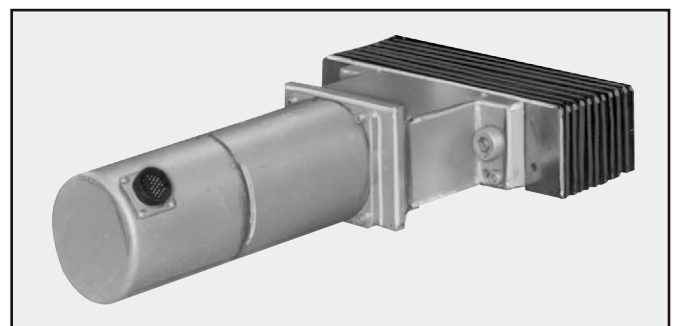

Super Select DS

Slides for Every Application

SINGLE SPEED AC/DC MOTOR DRIVE

Single Speed Motor Drives are the most economical motor drives offered and can be used in positioning applications where accuracy is not critical. Drives are available in AC or DC, from fractional hp to 3 hp, and are typically direct coupled to the ballscrew or feedscrew. The drive can be furnished with a torque limiting coupling to prevent overload damage to the motor. Traverse rates from 0.005 to 600 ipm can be provided, with proper selection of a gear box and various gear ratios (for extremely low feed rates).

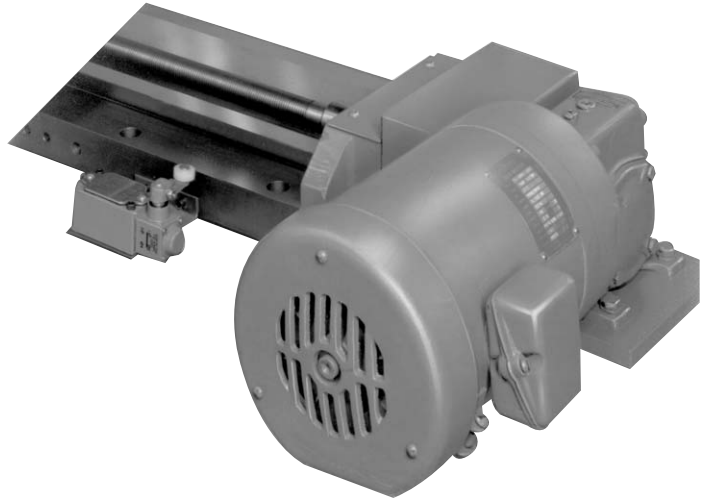

VARIABLE SPEED AC/DC MOTOR DRIVE

Variable Speed Motor Drives use the same motor as a 'Single Speed AC/DC Motor Drive' (above), with the addition of a speed control device for varying the slide traverse rate. The speed control device for an AC drive is a frequency inverter which typically allows a 6:1 speed range. In DC drive systems, the speed control device is a DC controller which allows approximately a 20:1 speed range.



LOW FRICTION BEARING MATERIAL

(Model Code: T)

This self-lubricating bearing material is bound to the gib and saddle way surfaces to reduce the effects of friction on the slide assembly. Low-friction minimizes "stick-slip", and makes wear negligible on both sliding surfaces.

The application of low-friction doubles the load carrying capacity of a slide. The co-efficient of friction with low-friction is 0.10; this drops to 0.05 when combined with a forced lubrication system. (When neither is used, the co-efficient of friction is 0.30.)

Low-friction material is recommended for high speed, high duty cycle applications, and in vertical applications where overhung load conditions exist.

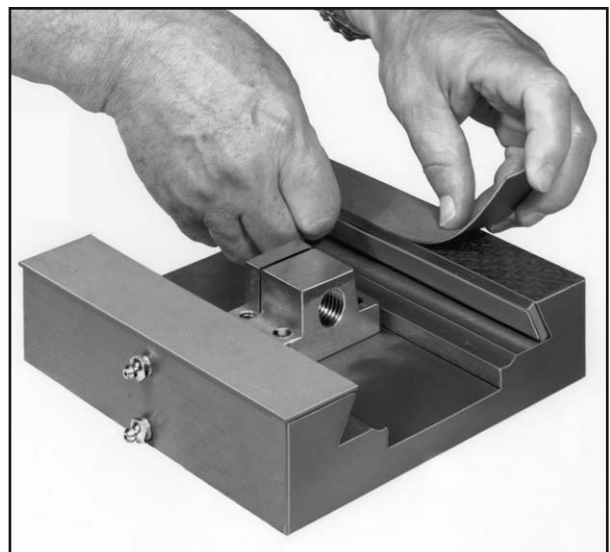

Super Select DS

Slides for Every Application

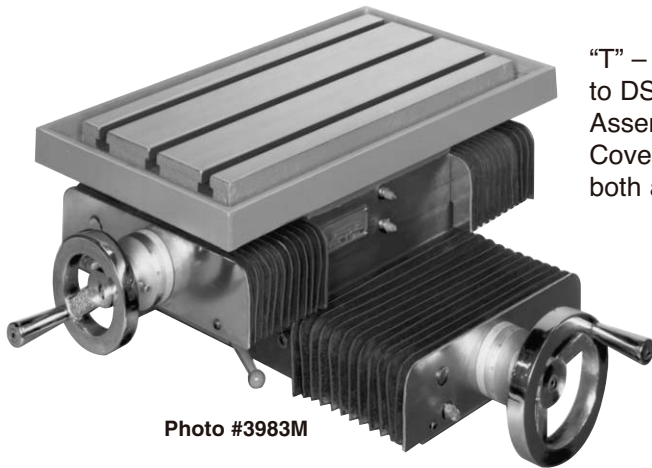
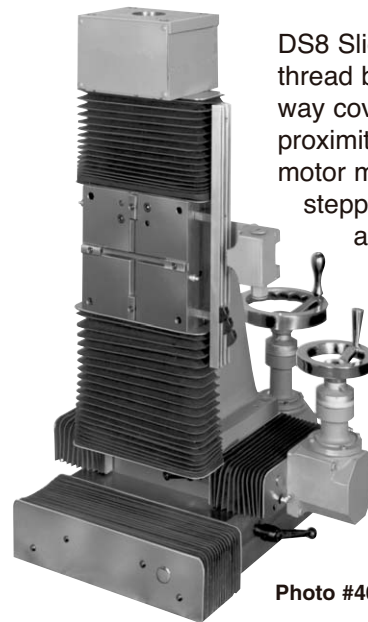

Photo #3983M

"T" – slotted worktable mounted to DS8 Compound Slide Assembly with Accordion Way Covers and Saddle Locks on both axes.



DS8 Slide with ground thread ballscrew, accordion way covers, limit switches, proximity switch, and motor mounting bracket and stepping motor mounts to an angle plate. Entire assembly is mounted to a DS16 Slide with accordion covers, two saddle locks, and right angle attachment.

Photo #4079M

Belt Driven Grinding Spindle with 3 HP "C" flange mounted motor. Mounted horizontal side wall to a DS10 Slide with Accordion Way Covers, Saddle Locks and Angle Plate mounted to a DS10 Slide with Accordion Way Covers and Saddle Locks.



Photo #4111M

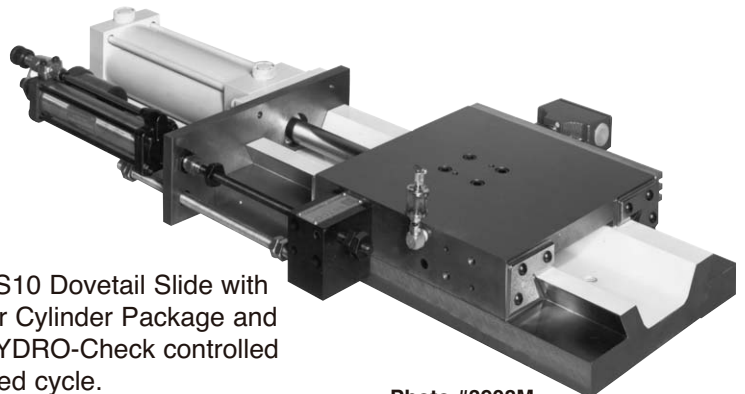

DS10 Dovetail Slide with Air Cylinder Package and HYDRO-Check controlled feed cycle.

Photo #3908M

Super Select DS

Slides for Every Application

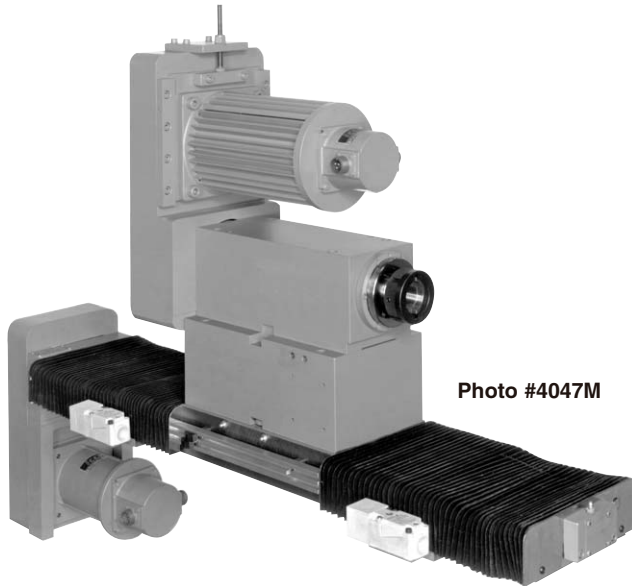

Photo #4047M

Type 4304MY Belt Driven Milling Spindle with 3 HP "C" flange mounted motor, belt and pulleys, belt guard, and belt tensioning. Mounted to a DS8 Slide with ground thread ballscrew and preloaded ballnut, accordion way covers and 2:1 belt drive package with servomotor.

DS12 Slide mounted to a vertical angle plate with complete motor drive package for spindles. Both saddles are manually positioned with separate feedscrews and ratchet handles.

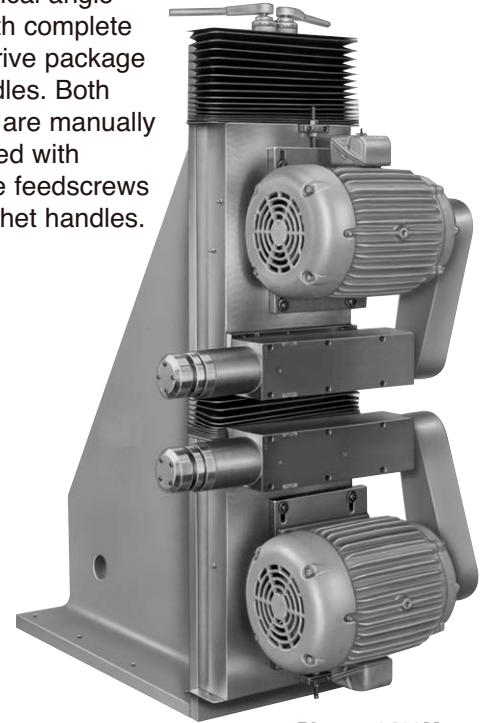

Photo #3483M

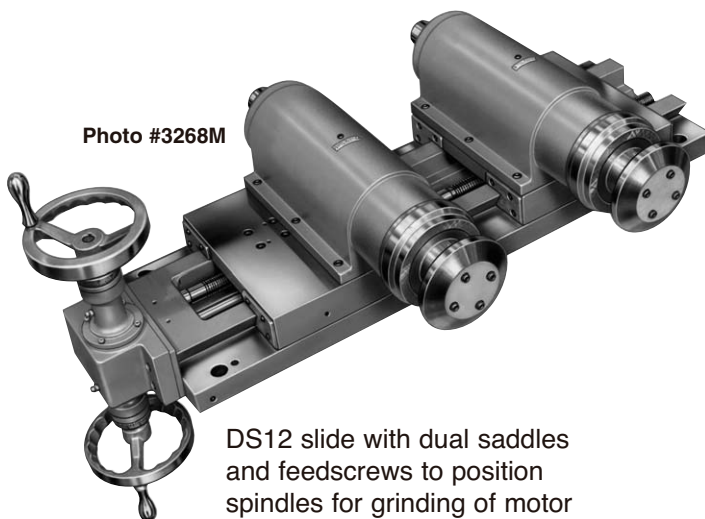
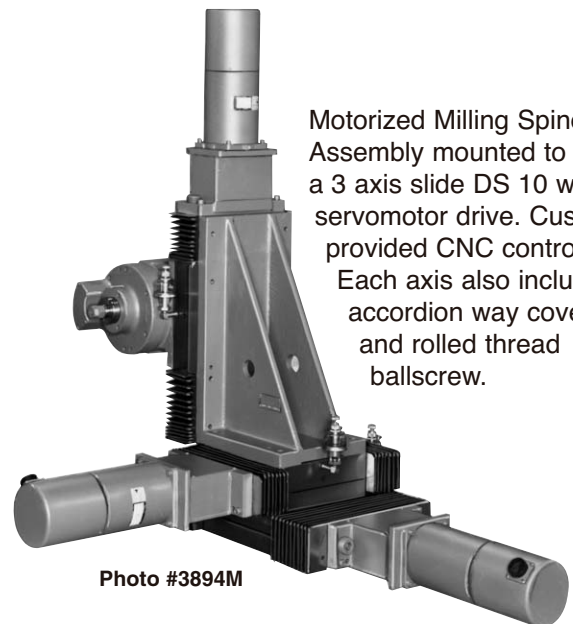

Photo #3268M

DS12 slide with dual saddles and feedscrews to position spindles for grinding of motor stator "halves" as stock is fed between wheels. The right angle attachment puts handwheel where most convenient or accessible to operator.



Motorized Milling Spindle Assembly mounted to a 3 axis slide DS 10 with servomotor drive. Customer provided CNC control. Each axis also includes accordion way covers and rolled thread ballscrew.

Photo #3894M

TS Series

Slide Model Code

HOW TO ORDER SLIDE

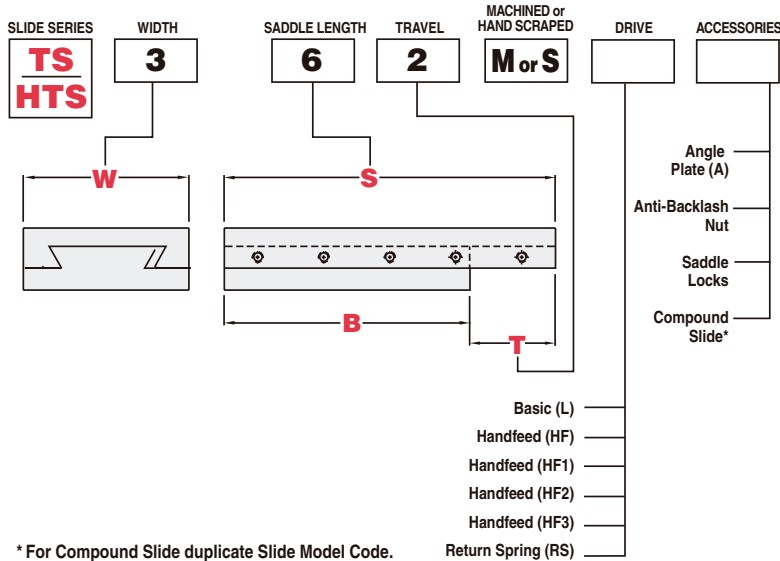

Easy Steps To TS Slide Selection

1. Choose slide width (inches).
2. Choose saddle length (inches).
3. Choose slide travel (inches).
4. Choose Machined or Hand-Scraped way surfaces.

INDEX

Page

Standard Duty

TS

Slide Width
2", 3", 4" or 6"

Basic

25

Hand Feed

26

Compound
Hand Feed

27

Vertical Angle
Plate with
Hand Feed

28

Return Spring

29

Heavy Duty

HTS

4", 6" or 8"

30

Basic

31

Hand Feed

32

Engineering Data
TS/HTS Series

33

To Place Your Order

Phone: 1-800-543-0470 Fax: 1-513-941-6913
Email: sales@setcousa.com

TS Series

- TS Slide Widths from 2" Thru 8"
- Immediate Off-the-Shelf Shipment
- Choice of Standard or Heavy Duty Slide Models

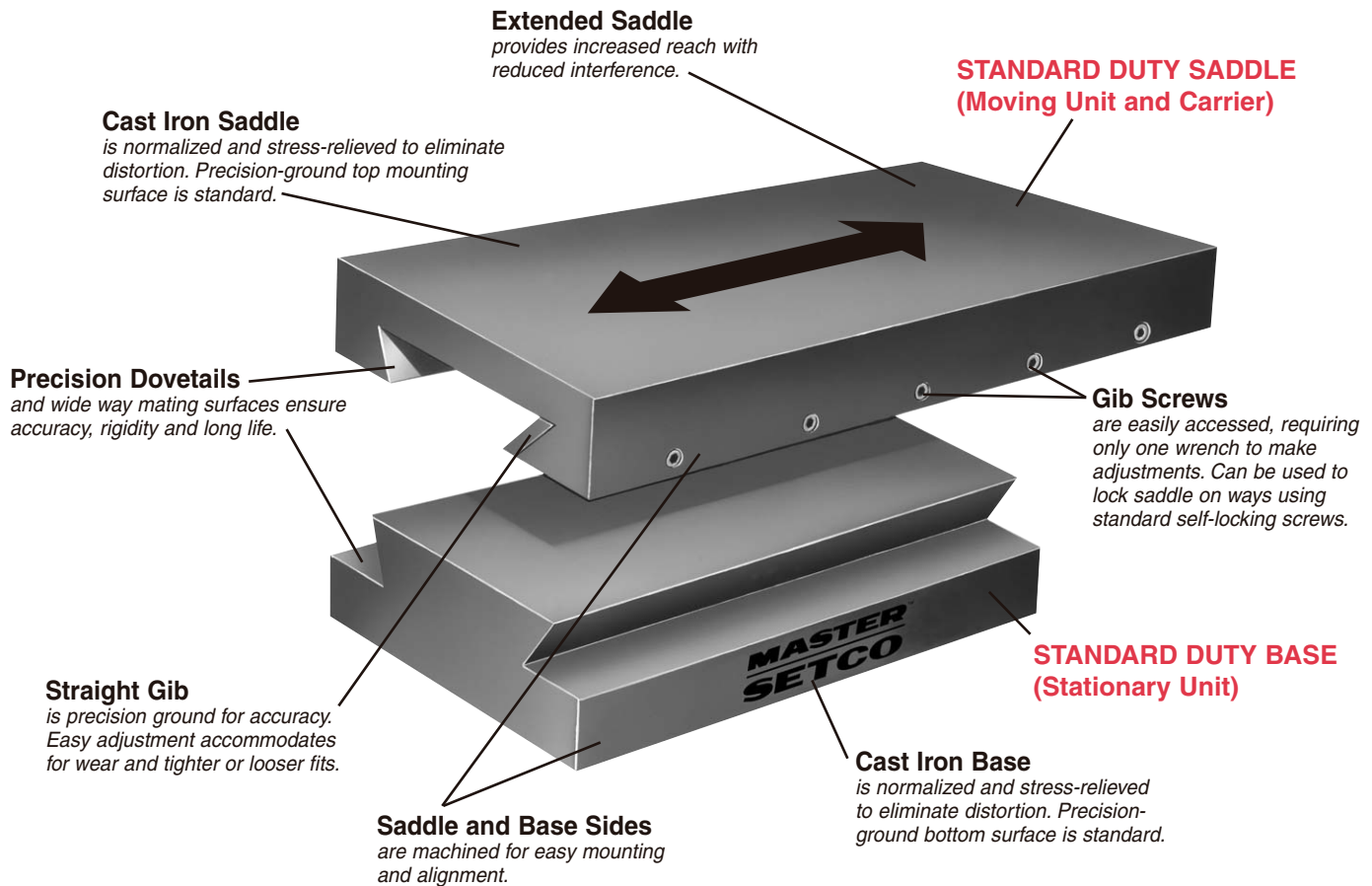

Quality Construction

The MASTER/SETCO TS Series Dovetail Slides are available in Standard Duty (above) or Heavy Duty (page 30) models. Design-matched to their particular range of applications, both configurations offer rugged design to ensure maximum life and accuracy.

Engineered to virtually eliminate distortion, both slide models feature bases and saddles manufactured from normalized and stress-relieved machine tool grade cast iron.

The Heavy Duty models feature a thicker base, saddle and dovetail cross section to enhance strength and stability. Lubrication fittings on each side of the base are also included as standard.

Top, bottom and side surfaces of both the Standard Duty and Heavy Duty models are ground flat and parallel. Most ordinary precision applications work well with ground way surfaces, however, optional hand-scraped surfaces are more readily suited to applications requiring greater accuracy, longer life and easier operation. Hand-scraping improves bearing surface contact and provides a closer fit between mating way surfaces.

When placing your order for off-the-shelf TS slides, use Item Code "M" for Machined surfaces; use "S" for Hand-Scraped surfaces.

Standard Duty TS Series

2", 3", 4", or 6"

BASIC

(No Feed Mechanism - Model Code: L)

The Standard Duty TS Dovetail Slides are used in applications where compactness of design is a must. This simple design has a minimum number of parts: base, saddle, gib and adjusting screws. Customer provides method of mounting and means of linear traverse.



MODEL NUMBER CODE

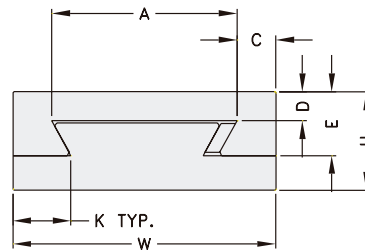
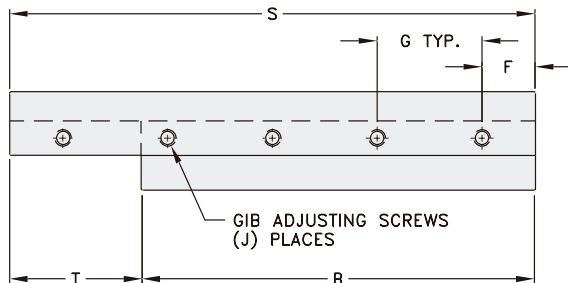
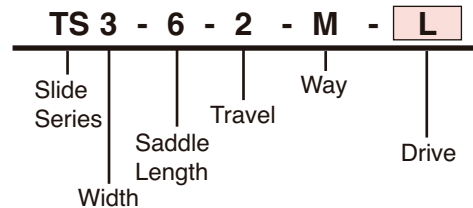

MODEL		DIMENSIONS IN INCHES													Weight (Lb.)	
Machined	Hand-Scraped	W	Saddle S	Base B	Travel T	Height H	A	C	D	E	F	G	J	K		
TS2-3-3/4-M-L	TS2-3-3/4-S-L	2.00	3.00	2.25	0.75	0.88	1.38	0.31	0.22	0.63	0.50	1.00	3	0.56	1.25	
TS2-4-1-M-L	TS2-4-1-S-L		4.00	3.00	1.00						0.59	1.41	3			1.50
TS2-6-2-M-L	TS2-6-2-S-L		6.00	4.00	2.00						0.75	1.50	4			
TS3-4-1-M-L	TS3-4-1-S-L	3.00	4.00	3.00	1.00	1.00	2.25	0.38	0.28	0.69	0.59	1.41	3	0.61	2.75	
TS3-5-1-M-L	TS3-5-1-S-L		5.00	4.00	1.00						0.63	1.25	4			3.50
TS3-6-2-M-L	TS3-6-2-S-L		6.00	4.00	2.00						0.75	1.50	4			
TS4-6-1-M-L	TS4-6-1-S-L	4.00	6.00	5.00	1.00	1.50	2.81	0.59	0.44	0.97	0.75	1.50	4	0.84	8.50	
TS4-8-2-M-L	TS4-8-2-S-L		8.00	6.00	2.00						0.81	1.59	5			11.00
TS4-12-3-M-L	TS4-12-3-S-L		12.00	9.00	3.00						1.03	1.66	7			
TS6-8-2-M-L	TS6-8-2-S-L	6.00	8.00	6.00	2.00	1.75	3.88	1.06	0.56	10.9	0.81	1.59	5	1.37	18.50	
TS6-12-4-M-L	TS6-12-4-S-L		12.00	8.00	4.00						1.03	1.66	7			27.00
TS6-16-4-M-L	TS6-16-4-S-L		16.00	12.00	4.00						1.00	1.75	9			

Standard Duty TS Series

2", 3", 4", or 6"

HAND FEED

(Single Axis Model Code: HF)

The Standard Duty TS Dovetail Slides with Hand Feed are used in applications requiring accurate manual feed or positioning. Smooth feed movement is achieved through a V threaded leadscrew and a micrometer dial graduated in 0.001" increments. An Acme threaded leadscrew, as noted by an asterisk (*) in the chart below, can be supplied at extra cost on Models TS4 and TS6.

Standard Duty Hand Feed models include a Ball Crank (HF 1, below). If space is limited, a Knurled Knob (HF 2) can be supplied. A Stub Shaft (HF 3) without a Ball Crank or Knob is available on request for applications where the customer's drive system is used.



MODEL NUMBER CODE

TS 3 - 6 - 2 - M - HF1

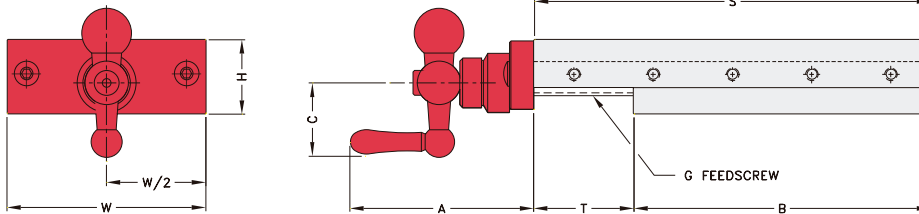
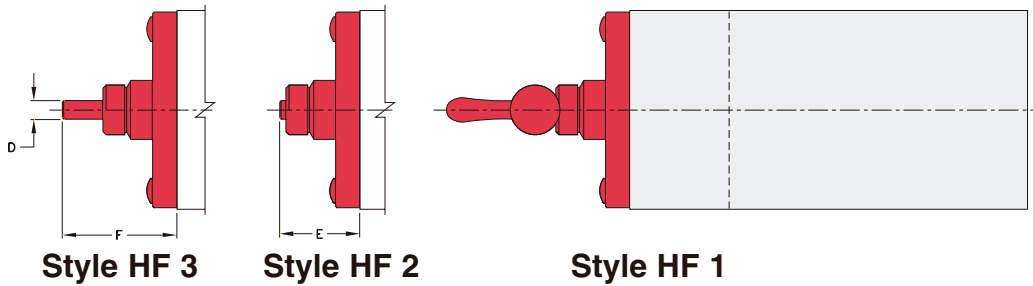
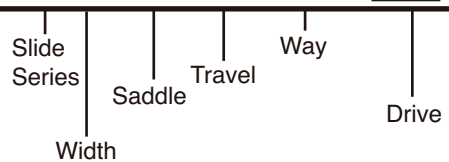

MODEL		DIMENSIONS IN INCHES											Weight (Lb.)		
Machined	Hand-Scraped	W	Saddle S	Base B	Travel T	Height H	A	C	D	E	F	G		R	
TS2-3-3/4-M-HF□	TS2-3-3/4-S-HF□	2.00	3.00	2.25	0.75	0.88	2.81	1.25	0.312	0.88	1.59	5/16-40 "V"	0.35	1.75	
TS2-4-1-M-HF□	TS2-4-1-S-HF□		4.00	3.00	1.00									2.00	2.00
TS2-6-2-M-HF□	TS2-6-2-S-HF□		6.00	4.00	2.00									2.00	2.00
TS3-4-1-M-HF□	TS3-4-1-S-HF□	3.00	4.00	3.00	1.00	1.00	2.81	1.25	0.312	0.88	1.59	5/16-40 "V"	0.38	3.25	
TS3-5-1-M-HF□	TS3-5-1-S-HF□		5.00	4.00	1.00									2.00	2.00
TS3-6-2-M-HF□	TS3-6-2-S-HF□		6.00	4.00	2.00									2.00	2.00
TS4-6-1-M-HF□	TS4-6-1-S-HF□	4.00	6.00	5.00	1.00	1.50	3.69	1.50	0.375	1.56	2.31	1/2-20 "V" or *1/2-10 ACME	0.63	9.50	
TS4-8-2-M-HF□	TS4-8-2-S-HF□		8.00	6.00	2.00									2.00	2.00
TS4-12-3-M-HF□	TS4-12-3-S-HF□		12.00	9.00	3.00									3.00	3.00
TS6-8-2-M-HF□	TS6-8-2-S-HF□	6.00	8.00	6.00	2.00	1.75	4.41	1.75	0.500	1.88	2.75	5/8-20 "V" or *5/8-10 ACME	0.69	21.25	
TS6-12-4-M-HF□	TS6-12-4-S-HF□		12.00	8.00	4.00									4.00	4.00
TS6-16-4-M-HF□	TS6-16-4-S-HF□		16.00	12.00	4.00									4.00	4.00

□ = HF 1, 2, or 3

Standard Duty TS Series

2", 3", 4", or 6"

COMPOUND HAND FEED

The versatile Standard Duty TS Dovetail Slides can be used for applications requiring accurate 2-axis positioning or feeding. This is accomplished by combining two standard leadscrew slide assemblies. These units are bolted together, aligned and doweled in position at 90° to provide accurate, coordinated X- and Y-axis movements.

Mounting holes are provided in the base of the bottom slide unit for easy installation. Consult factory for availability of other assembly combinations.

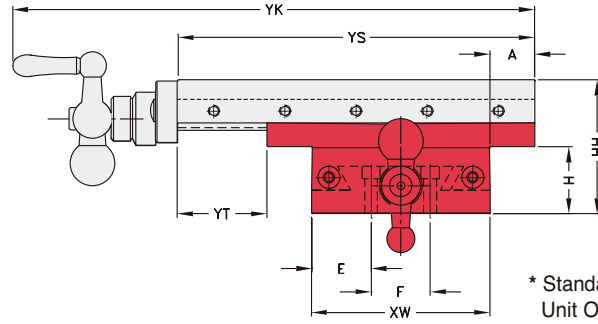
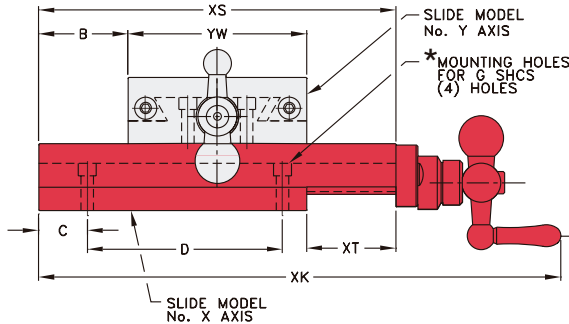
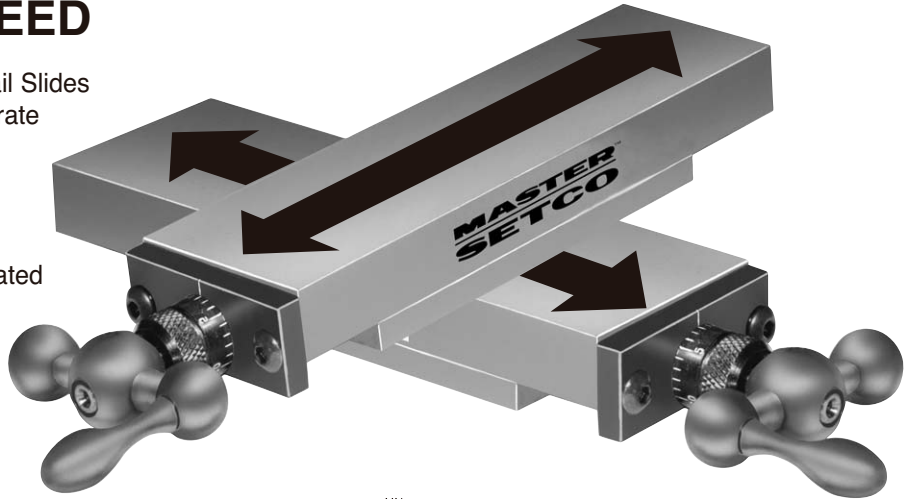

MODEL NUMBER CODE

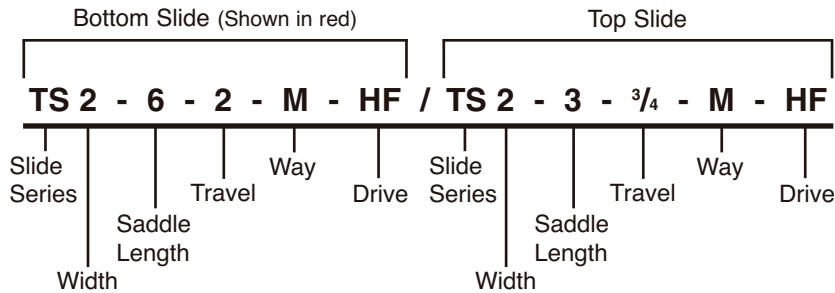

MODEL		DIMENSIONS IN INCHES																	Weight (Lb.)
Machined	Hand-Scraped	XW	YW	Saddle Travel			Saddle Travel			Height		A	B	C	D	E	F	G	
				XS	XT	XK	YS	YT	YK	H	HH								
TS2-6-2-M-HF/TS2-3-3/4-M-HF	TS2-6-2-S-HF/TS2-3-3/4-S-HF	2.00	2.00	6.00	2.00	8.81	3.00	0.75	5.81	0.88	1.75	0.12	2.00	0.25	2.75	0.69	0.44	#8	3.50
TS2-4-1-M-HF/TS2-4-1-M-HF	TS2-4-1-S-HF/TS2-4-1-S-HF	2.00		4.00	1.00	6.81	4.00	1.00	6.81	0.88	1.75	0.50	1.00	0.25	1.75	0.69	0.4	#8	3.00
TS3-6-2-M-HF/TS2-6-2-M-HF	TS3-6-2-S-HF/TS2-6-2-S-HF	3.00	3.00	6.00	2.00	8.81	6.00	2.00	8.81	1.00	1.88	0.50	2.00	0.38	3.25	0.94	1.12	#10	6.00
TS3-6-2-M-HF/TS3-4-1-M-HF	TS3-6-2-S-HF/TS3-4-1-S-HF	3.00		6.00	2.00	8.81	4.00	1.00	6.81	1.00	2.00	0.00	1.50	0.38	3.25	0.94	1.12	#10	6.50
TS3-5-1-M-HF/TS3-5-1-M-HF	TS3-5-1-S-HF/TS3-5-1-S-HF	3.00	3.00	5.00	1.00	7.81	5.00	1.00	7.81	1.00	2.00	0.50	1.00	0.38	3.25	0.94	1.12	#10	7.00
TS4-12-3-M-HF/TS3-6-2-M-HF	TS4-12-3-S-HF/TS3-6-2-S-HF	4.00		12.00	3.00	15.69	6.00	2.00	8.81	1.50	2.50	0.00	4.50	0.63	7.75	1.38	1.12	1/4	20.25
TS4-12-3-M-HF/TS4-6-1-M-HF	TS4-12-3-S-HF/TS4-6-1-S-HF	4.00	4.00	12.00	3.00	15.69	6.00	1.00	9.69	1.50	3.00	0.50	4.00	0.63	7.75	1.38	1.25	1/4	25.00
TS4-8-2-M-HF/TS4-8-2-M-HF	TS4-8-2-S-HF/TS4-8-2-S-HF	4.00		8.00	2.00	11.69	8.00	2.00	11.69	1.50	3.00	1.00	2.00	0.63	4.75	1.38	1.25	1/4	22.00
TS6-12-4-M-HF/TS4-12-3-M-HF	TS6-12-4-S-HF/TS4-12-3-S-HF	6.00	6.00	12.00	4.00	16.41	12.00	3.00	15.69	1.75	3.25	1.50	4.00	0.75	6.50	1.88	2.25	5/16	43.50
TS6-12-4-M-HF/TS6-8-2-M-HF	TS6-12-4-S-HF/TS6-8-2-S-HF	6.00		12.00	4.00	16.41	8.00	2.00	12.41	1.75	3.50	0.00	3.00	0.75	6.50	1.88	2.25	5/16	45.50
TS6-12-4-M-HF/TS6-12-4-M-HF	TS6-12-4-S-HF/TS6-12-4-S-HF	6.00	6.00	12.00	4.00	16.41	12.00	4.00	16.41	1.75	3.50	1.00	3.00	0.75	6.50	1.88	2.25	5/16	54.00
HTS8-16-6-M-HF/TS6-16-4-M-HF	HTS8-16-6-S-HF/TS6-16-4-S-HF	8.00		16.00	6.00	20.38	16.00	4.00	20.41	2.75	4.50	2.00	5.00	2.50	5.00	2.75	2.5	5/16	135.00

Standard Duty TS Series

2", 3", 4", or 6"

VERTICAL ANGLE PLATE With HAND FEED (Single Axis Model Code: A)

Bolting a Standard Duty TS Hand Feed Slide assembly to a Vertical Angle Plate can simply and inexpensively solve many of your application problems. For even greater operational flexibility, we can create a 3-axis slide unit by bolting a Compound (2-axis) Slide Assembly to a single-axis hand feed unit which has been mounted on the face of an angle plate.

All dimensions and features of the standard hand feed units apply to these fully integrated assemblies. Angle plates are standard with mounting holes in the base for easy installation.

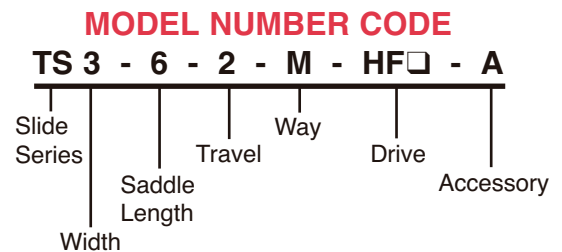
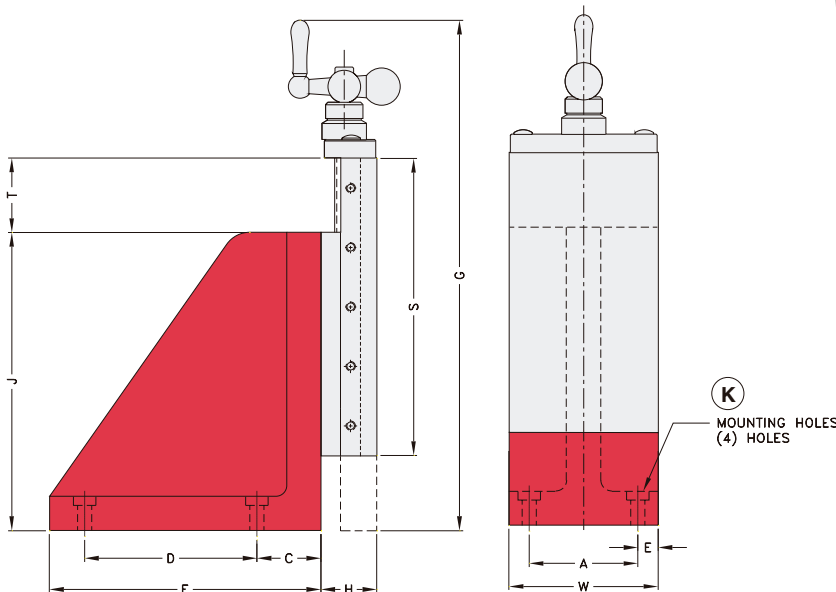

MODEL		DIMENSIONS IN INCHES											Weight (Lb.)	
Machined	Hand-Scraped	W	Saddle S	Travel T	Height H	A	C	D	E	F	G	J		K
TS2-3-3/4-M-HF□A	TS2-3-3/4-S-HF□A	2.00	3.00	0.75	0.88	1.63	0.63	1.12	0.19	2.00	6.56	3.00	#8	3.00
TS2-4-1-M-HF□A	TS2-4-1-S-HF□A		4.00	1.00							7.81	4.00		3.50
TS2-6-2-M-HF□A	TS2-6-2-S-HF□A		6.00	2.00							10.81	6.00		4.75
TS3-4-1-M-HF□A	TS3-4-1-S-HF□A	3.00	4.00	1.00	1.00	2.50	0.75	2.00	0.25	3.00	7.81	4.00	#10	7.00
TS3-5-1-M-HF□A	TS3-5-1-S-HF□A		5.00	1.00							8.81	5.00		8.75
TS3-6-2-M-HF□A	TS3-6-2-S-HF□A		6.00	2.00							10.81	6.00		9.50
TS4-6-1-M-HF□A	TS4-6-1-S-HF□A	4.00	6.00	1.00	1.50	3.38	1.00	2.63	0.31	4.00	10.69	6.00	1/4	20.25
TS4-8-2-M-HF□A	TS4-8-2-S-HF□A		8.00	2.00							13.69	8.00		24.75
TS4-12-3-M-HF□A	TS4-12-3-S-HF□A		12.00	3.00							18.69	12.00		33.50
TS6-8-2-M-HF□A	TS6-8-2-S-HF□A	6.00	8.00	2.00	1.75	5.25	1.25	4.25	0.38	6.00	14.41	8.00	5/16	47.00
TS6-12-4-M-HF□A	TS6-12-4-S-HF□A		12.00	4.00							20.41	12.00		62.00
TS6-16-4-M-HF□A	TS6-16-4-S-HF□A		16.00	4.00							24.41	16.00		78.00

□ = HF 1, 2, or 3 See page 26 for handle/knob styles.

Standard Duty TS Series

2", 3", 4", or 6"

RETURN SPRING

(Single Axis Model Code: RS)

The Standard Duty TS Dovetail Slide equipped with Return Spring operation is used in applications requiring powered reverse travel. In operation, once the saddle is moved forward on its base by a cam or other external means, the saddle is automatically and quickly powered back to its starting position by the Return Spring.

To ensure long life and positive cycling, the Return Spring mechanism is made from high quality die springs. When an overriding cam is used, the forward travel stroke is precisely limited by an adjustable stop screw. Mounting holes are machined into the base to facilitate ease of installation.

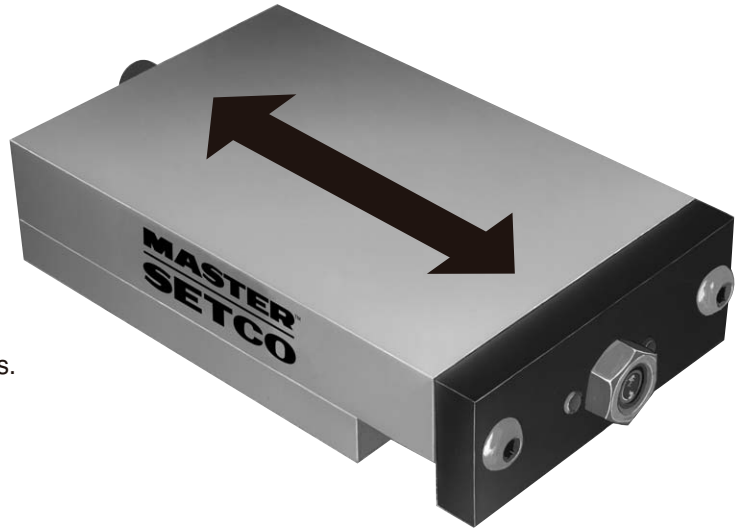

MODEL NUMBER CODE

TS 3 - 6 - 2 - M - RS

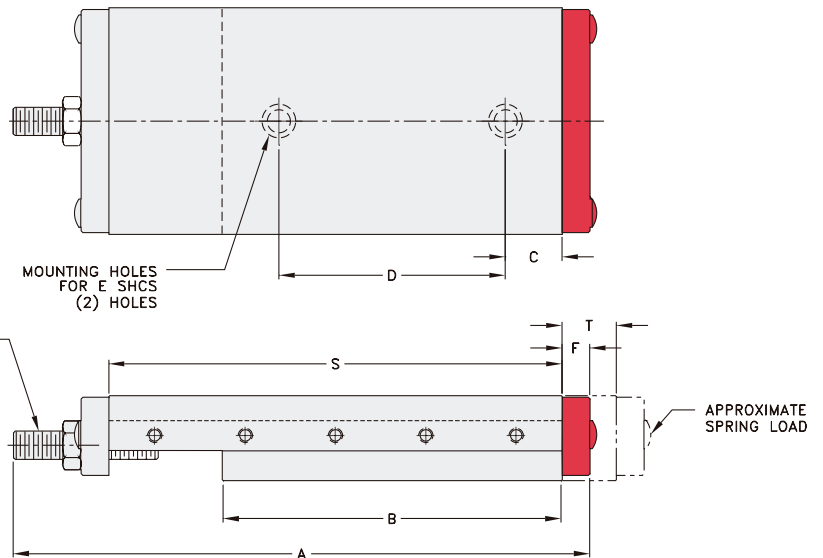
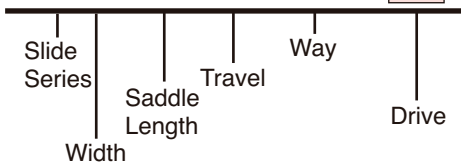

MODEL		DIMENSIONS IN INCHES										Spring Loads		Weight (Lb.)
Machined	Hand Scraped	W	Saddle S	Base B	Travel T	Height H	A	C	D	E	F	MIN	MAX	
TS2-3-3/4-M-RS	TS2-3-3/4-S-RS	2.00	3.00	2.25	0.38	0.88	3.88	0.25	.88	1/4	0.32	16	23	1.50
TS2-4-1-M-RS	TS2-4-1-S-RS		4.00	3.00	0.50		5.00		1.25			16	23	1.75
TS2-6-2-M-RS	TS2-6-2-S-RS		6.00	4.00	0.75		7.63		1.75			17	23	2.50
TS3-4-1-M-RS	TS3-4-1-S-RS	3.00	4.00	3.00	0.75	1.00	5.00	0.63	1.75	5/16	0.32	19	47	3.00
TS3-5-1-M-RS	TS3-5-1-S-RS		5.00	4.00	0.63		6.00		2.75			23	47	3.75
TS3-6-2-M-RS	TS3-6-2-S-RS		6.00	4.00	0.75		7.75		2.75			30	45	4.00
TS4-6-1-M-RS	TS4-6-1-S-RS	4.00	6.00	5.00	0.75	1.50	7.25	1.00	3.00	3/8	0.61	64	112	9.00
TS4-8-2-M-RS	TS4-8-2-S-RS		8.00	6.00	1.00		9.75		4.00			64	112	11.50
TS4-12-3-M-RS	TS4-12-3-S-RS		12.00	9.00	1.50		14.25		7.00			63	108	17.00
TS6-8-2-M-RS	TS6-8-2-S-RS	6.00	8.00	6.00	1.00	1.75	10.00	1.00	4.00	1/2	0.61	142	202	20.50
TS6-12-4-M-RS	TS6-12-4-S-RS		12.00	8.00	1.50		15.00		6.00			148	202	29.00
TS6-16-4-M-RS	TS6-16-4-S-RS		16.00	12.00	2.00		19.00		10.00			141	202	40.00

Heavy Duty HTS Series

- HTS Slide Widths 4", 6" or 8"
- Thicker Base, Saddle and Dovetail Cross-Section
- Base Includes Lubrication Fittings

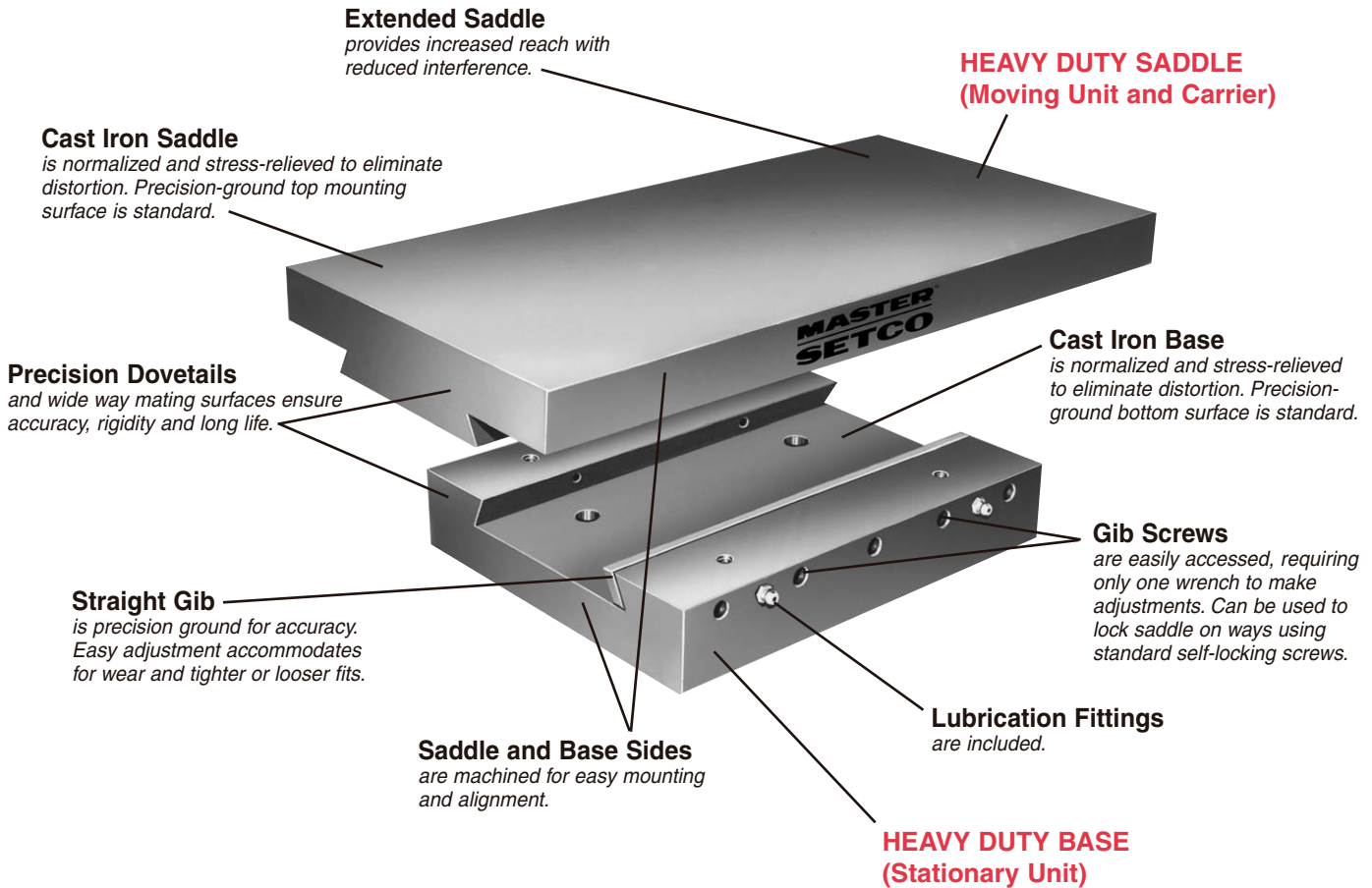

Accessories:

- Force Feed Lubrication
- Adjustable Anti-Backlash Leadscrew Nuts
- Saddle Locks
- Machined or Hand-Scraped Surfaces

Heavy Duty HTS Series 4", 6" or 8"

BASIC

(No Feed Mechanism Model Code: L)

The Heavy Duty HTS Dovetail Slides have been designed for applications requiring more rigidity and stability than the Standard Duty Dovetail Slides. This includes thicker base, saddle and dovetail cross sections.

Mounting holes are machined into the base to facilitate ease of installation. And because the base/saddle is thicker, additional mounting holes and keyways can easily be incorporated.

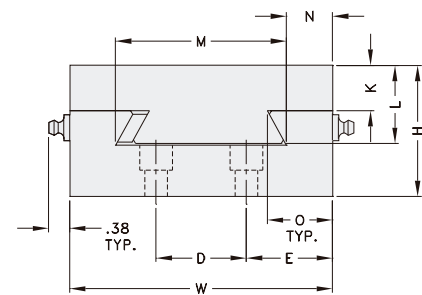
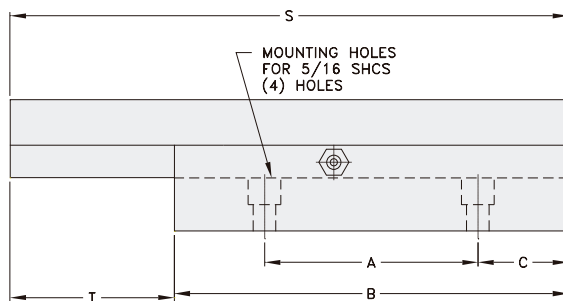
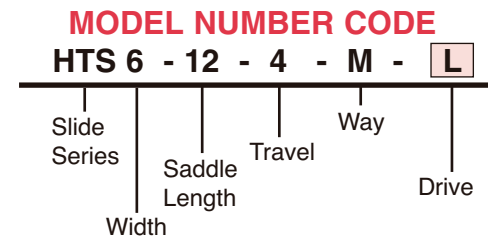
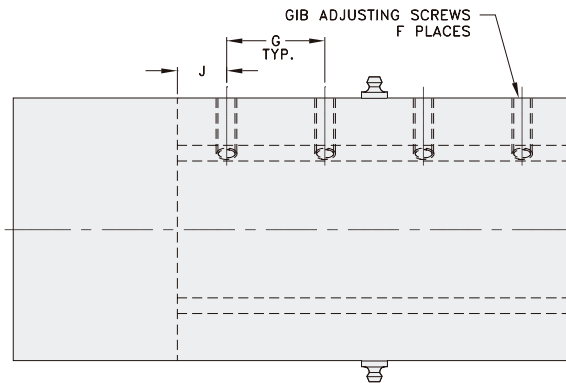

MODEL		DIMENSIONS IN INCHES																	Weight (Lb.)
Machined	Hand-Scraped	W	S	B	T	H	A	C	D	E	F	G	J	K	L	M	N	O	
HTS4-8-2-M-L	HTS4-8-2-S-L	4	8.00	6.00	2.00	2.00	3.25	1.38	1.38	1.31	4	1.50	0.75	0.69	1.19	2.56	.72	1.22	20.0
HTS4-12-4-M-L	HTS4-12-4-S-L		12.00	8.00	4.00			2.38			5		1.00						28.0
HTS6-12-4-M-L	HTS6-12-4-S-L	6	12.00	8.00	4.00	2.75	5.00	1.50	2.50	1.75	4	2.00	1.00	0.94	1.56	3.75	1.12	1.74	55.0
HTS6-16-6-M-L	HTS6-16-6-S-L		16.00	10.00	6.00			2.50			5		1.00						76.0
HTS8-16-6-M-L	HTS8-16-6-S-L	8	16.00	10.00	6.00	2.75	5.00	2.50	2.50	2.75	5	2.00	1.00	0.94	1.56	4.69	1.66	2.28	97.0
HTS8-24-12-M-L	HTS8-12-12-S-L		24.00	12.00	12.00			3.50			6		1.00						133.0

Heavy Duty HTS Series 4", 6" or 8"

HAND FEED

(Single Axis Model Code: HF)

The Heavy Duty HTS Dovetail Slides with Hand Feed are used in applications requiring accurate manual feed or positioning of heavier work or materials.

Smooth manual feed is achieved through an Acme threaded leadscrew and a micrometer dial graduated in 0.001" increments. Backlash adjustment is an available option.

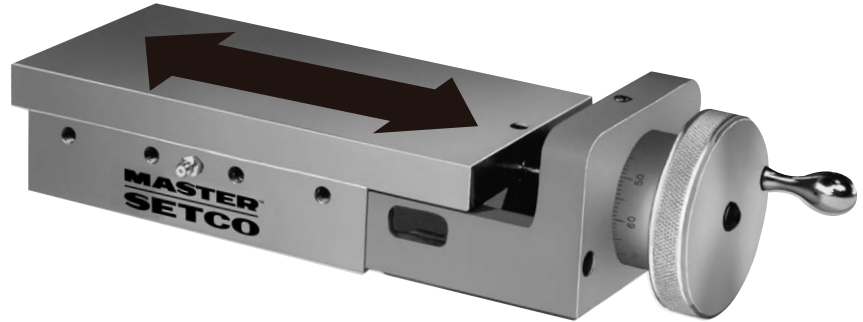

MODEL NUMBER CODE

HTS 6 - 12 - 4 - M - HF

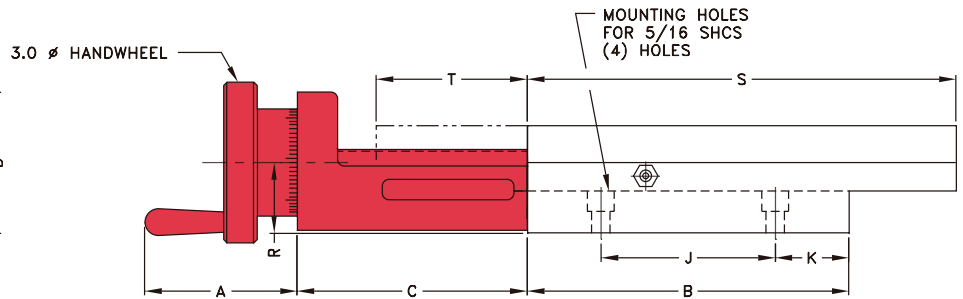
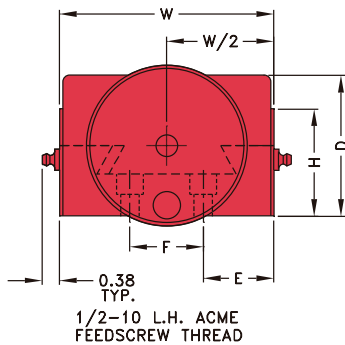
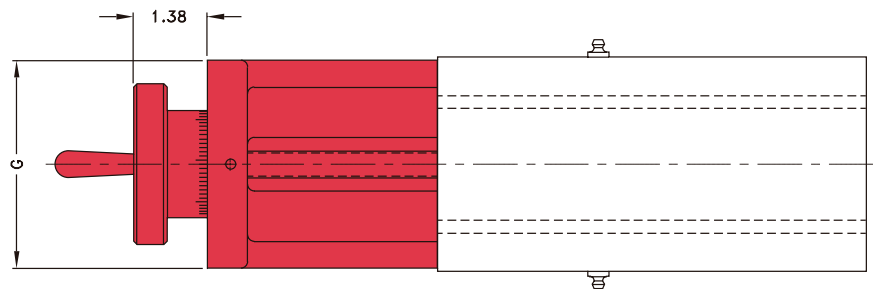
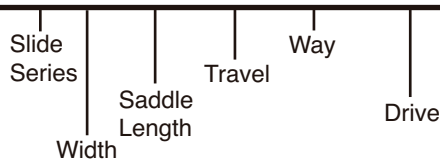

MODEL		DIMENSIONS IN INCHES														Weight (Lb.)
Machined	Hand-Scraped	W	Saddle S	Base B	Travel T	Height H	A	C	D	E	F	G	J	K	R	
HTS4-8-2-M-HF	HTS4-8-2-S-HF	4	8.00	6.00	2.00	2.00	2.88	3.50	2.69	1.31	1.38	3.88	3.25	1.38	1.31	24
HTS4-12-4-M-HF	HTS4-12-4-S-HF		12.00	8.00	4.00			5.50						2.38		
HTS6-12-4-M-HF	HTS6-12-4-S-HF	6	12.00	8.00	4.00	2.75	2.88	5.50	3.12	1.75	2.50	5.88	5.00	1.50	1.81	63
HTS6-16-6-M-HF	HTS6-16-6-S-HF		16.00	10.00	6.00			7.50						2.50		
HTS8-16-6-M-HF	HTS8-16-6-S-HF	8	16.00	10.00	6.00	2.75	2.88	7.50	3.12	2.75	2.50	7.88	5.00	2.50	1.81	110
HTS8-24-12-M-HF	HTS8-24-12-S-HF		24.00	12.00	12.00			13.50						3.50		

Engineering Data TS/HTS Series

The values listed in the Load Chart have been formulated for standard length saddles for convenience in proper slide selection. The forces (P) and moments (M) in Figure 1 have been shown as positive in a right hand coordinate system. Application forces and moments should be summed using a consistent sign convention.

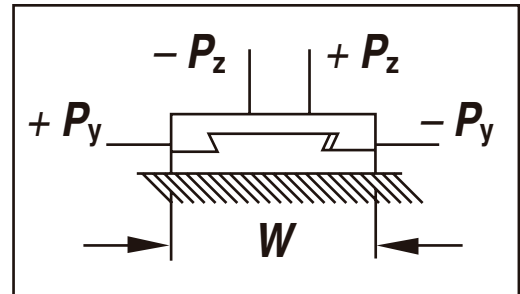

LOAD CAPACITY							
Width W	$-P_z$ (lb)	$+P_z$ (lb)	$+P_y$ (lb)	$-P_y$ (lb)	M_x (in·lb)	M_y (in·lb)	M_z (in·lb)
TS2-3-3/4	44	22	13	6	12	19	6
TS2-4-1	59	30	17	8	16	25	11
TS2-6-2	78	40	23	11	22	34	18
TS3-4-1	71	36	17	8	31	40	11
TS3-5-1	94	47	23	11	42	54	18
TS3-6-2	94	47	23	11	42	54	18
TS4-6-1	156	78	38	19	91	118	39
TS4-8-2	187	93	46	23	109	141	55
TS4-12-3	281	140	70	35	163	212	119
TS6-8-2	291	145	58	29	258	267	70
TS6-12-4	386	193	77	38	343	354	121
TS6-16-4	581	290	116	58	522	533	265
HTSA4-8-2	198	100	58	28	113	167	78
HTSA4-12-4	261	130	77	38	148	221	132
HTSA6-12-4	409	205	92	46	355	397	158
HTSA6-16-6	508	254	116	58	440	493	247
HTSA8-16-6	750	375	116	58	839	322	255
HTSA8-24-12	896	400	139	70	1002	381	355

DEFINITIONS
M_x = Moment about x axis (in·lb)
M_y = Moment about y axis (in·lb)
M_z = Moment about z axis (in·lb)
P_x = Load in the x direction
P_y = Load in the y direction
P_z = Load in the z direction
x = Moment arm distance (in)
y = Moment arm distance (in)
z = Moment arm distance (in)

$$M_x = P_z(y) - P_y(z)$$

$$M_y = P_x(z) - P_z(x)$$

$$M_z = P_y(x) - P_x(y)$$

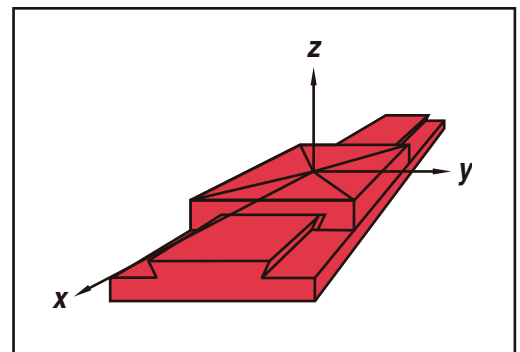
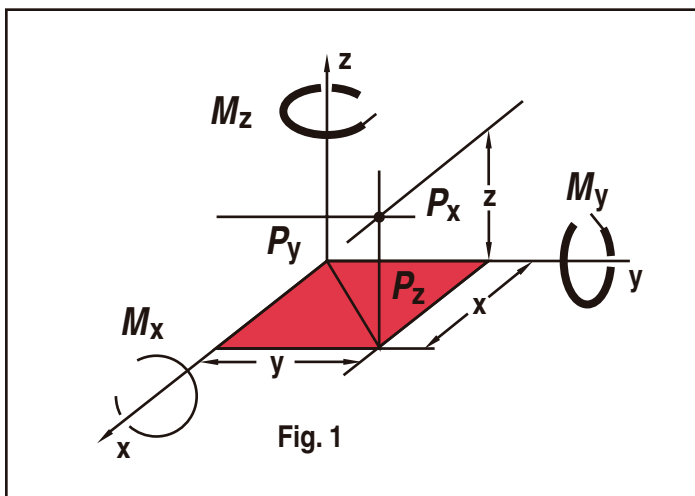

M Series

- In-Stock Slide Widths from 2" Thru 10"
- Immediate Shipment
- Standard with Hand Feed Package
- Common Accessories Readily Available

Quality Construction

The M Series is a precision line of off-the-shelf dovetail slide assemblies equipped with manual feed. The hand feed package includes a milled thread Acme leadscrew, bronze nut with anti-backlash compensation, and hand-wheel with micrometer dial graduated in 0.001" increments. Ideal applications include positioning fixtures, workholding devices, checking fixtures, gauges, assembly equipment, etc.

M Series slides are engineered to virtually eliminate distortion using a base and saddle manufactured from normalized and stress-relieved machine tool grade cast iron. The saddle top and way surfaces are precision ground. Way surfaces are machined with oil grooves to ensure proper oil retention, improve bearing surface contact and provide a closer fit between mating way surfaces.*

As standard, the M Series is available only in the slide lengths and with the accessories specified in this catalog. Contact the factory for additional non-standard sizes; M5, M6, and M7. When custom lengths and other accessories are required, select slides from our MASTER/SETCO DS Series. Call our toll-free number for factory assistance.

*M0 Saddle Top and Way Surfaces are not ground and do not have Z Oil Grooves.

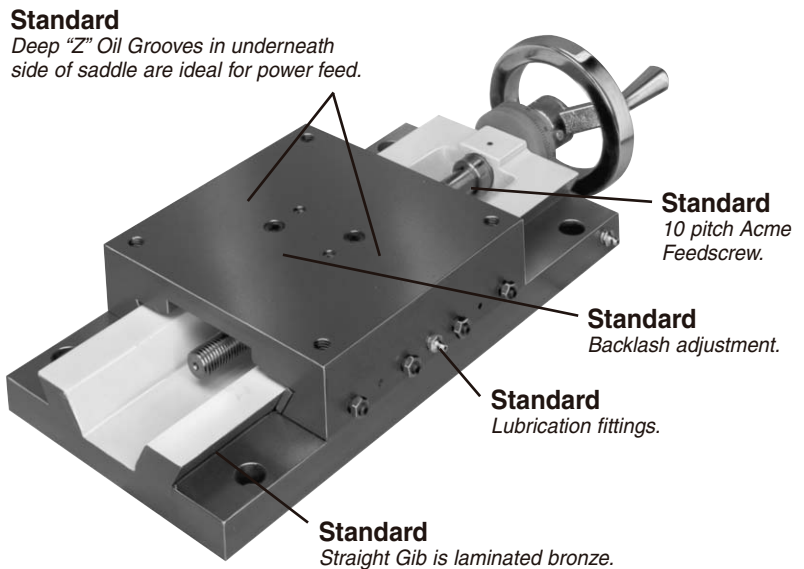

Slide Load Capacity Chart

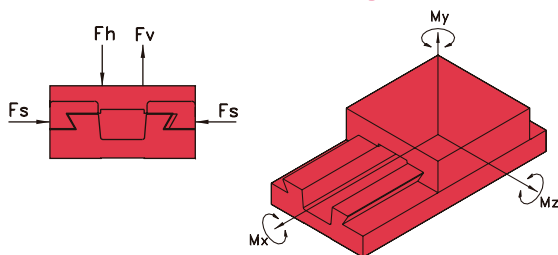

- Notes:** 1. For applications where load is applied in the direction of slide travel, the slide load capacity may be limited to the capacity of the slide feed mechanism. Check the load values with the maximum thrust capacities for the feed mechanism being used.

For static applications, the slide load capacity may be limited by the saddle locking device.

Slide load capacity is based on uniformly applied loads and moments. Consult factory on all applications where shock loading is present.

2. For applications involving an Mx moment, the slide load capacity may be limited by the Fs Load capacity.

Data based on calculations at 25 psi:

MODEL	Fh (Lb.)	Fv (Lb.)	Fs (Lb.)	Mx* (Lb.)	My* (Lb.)	Mz* (Lb.)
M0	115	60	50	25	35	90
M1	265	75	65	105	100	180
M2	360	75	65	165	100	180
M3	705	175	150	185	300	575
M4	1165	290	250	980	625	1440

How To Order

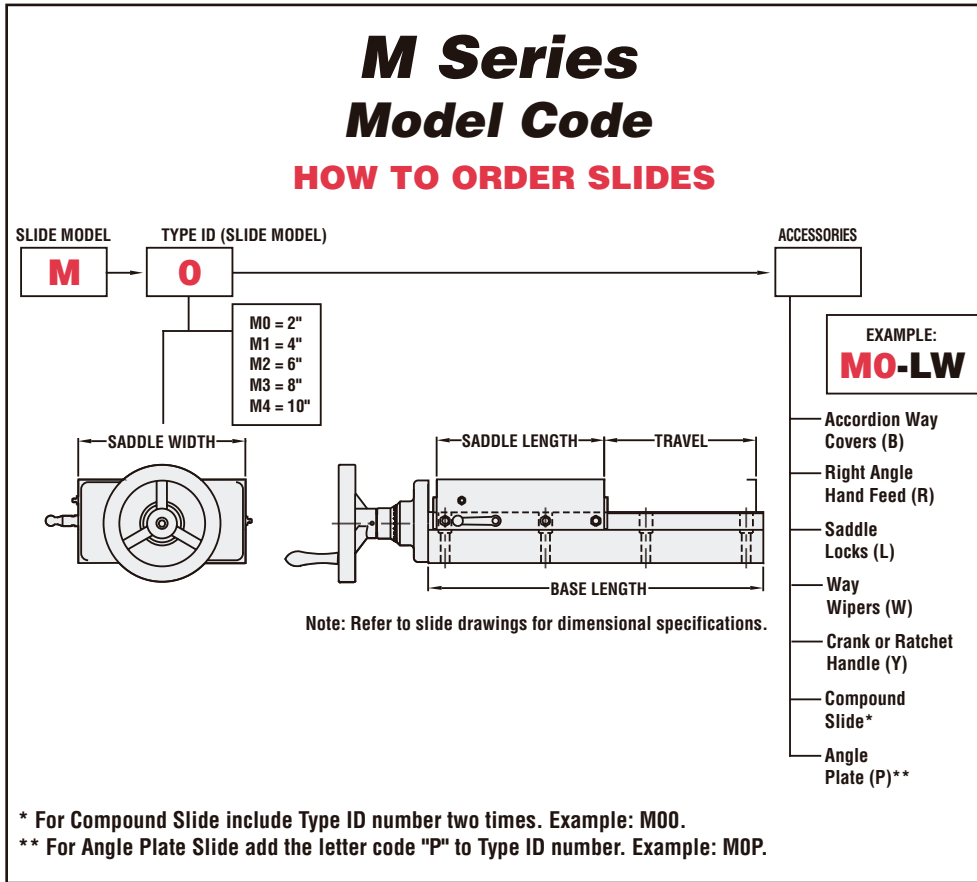

INDEX

Page

M Series

Slide Width	
Type M0: 2"	36
Type M1: 4"	37
Type M2: 6"	38
Type M3: 8"	39
Type M4: 10"	40
Accessories	41-45
Application Photos	46-47
Design Data DS/M Series	48-51

At-A-Glance, M Series

- **Saddle**—The moving member and carrier. Manufactured from fine grain 40,000 PSI tensile gray iron, stress relieved and properly normalized for minimal distortion. SADDLE top and way surfaces are precision ground, with way surfaces oil grooved and hand-flaked to ensure proper oil retention.
- **Base**—The stationary member. Manufactured from fine grain 40,000 PSI tensile gray iron, stress relieved and properly normalized for minimal distortion. BASE top and bottom are precision ground.
- **Straight Gib**—Adjustable member for setting slide clearances between saddle and ways. Manufactured from wear resistant laminated bronze. Way surfaces are precision ground, oil grooved and fitted to ensure long lasting operation.
- **Gib Adjusting Screws**—Socket set screws properly spaced along gib side of saddle for adjusting gib.
- **Gib Screw Nuts**—Hex jam nuts which lock the gib adjusting screws in place, maintaining gib adjustment.
- **Gib Pin**—Straight pin to retain linear positioning of gib.
- **Lubrication Fittings**—For pressure gun lubrication. Can be removed for manual or automatic systems. Mobil Vactra #2 way oil or equivalent is recommended.

To Place Your Order

Phone: 1-800-543-0470 Fax: 1-513-941-6913
 Email: sales@setcousa.com

M Series: Type M0

2"

M0 HAND FEED

(Single Axis • Weight: 3.25 lb. • Feedscrew 5/16-40)

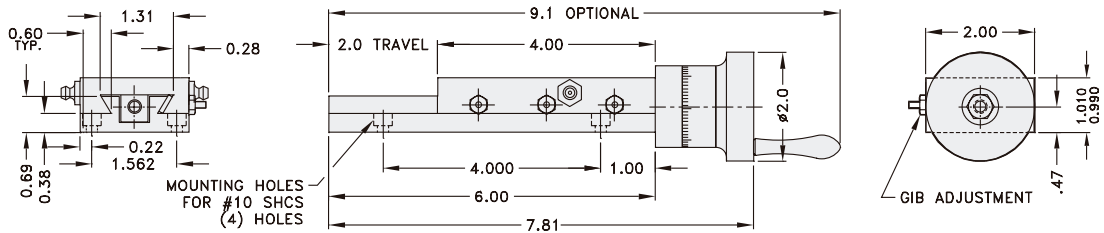

M00 COMPOUND HAND FEED

(2-Axis • Weight: 6.5 lb.)

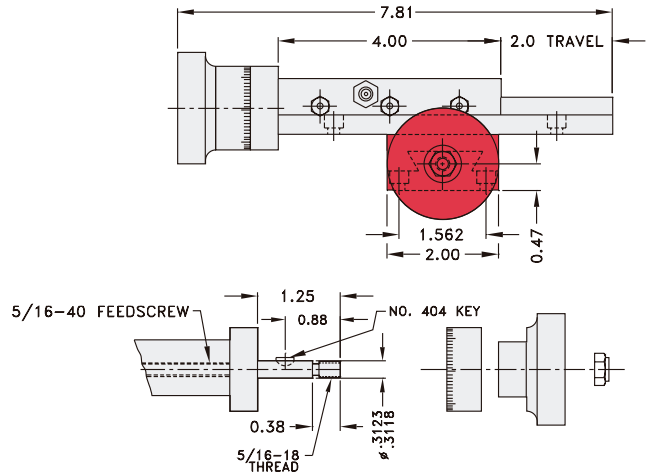
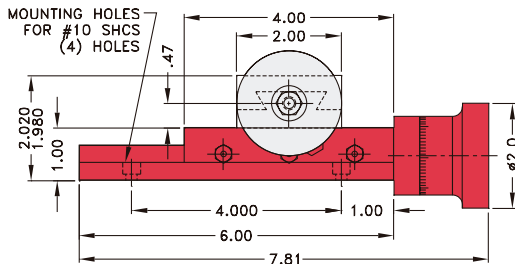

- Torque required to turn M0 feedscrew is about 5 in/lb.
- When the slide is mounted to a sidewall with its feedscrew at right angles to the vertical plane, the gib must be on the bottom. (See Slide Mounting Attitude, page 48.)
- For load capacities, see Slide Load Capacity chart, page 50.
- Slides can be supplied without a micrometer handwheel, allowing use of a ratchet handle, crank or other device.

M0P VERTICAL ANGLE PLATE WITH HAND FEED

(Single Axis • Weight: 7 lb.)

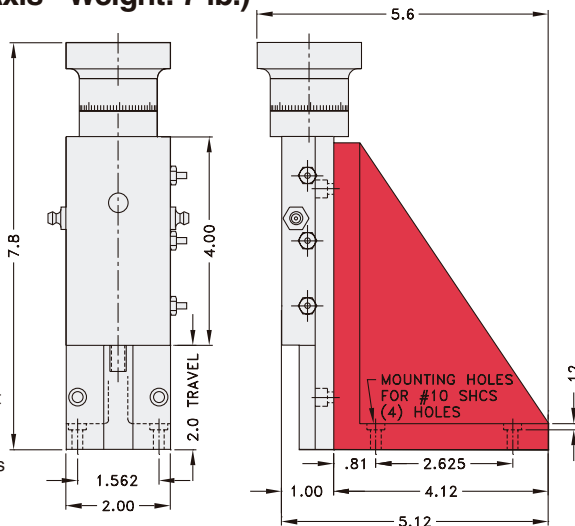

- Load capacity is measured at the saddle; overhanging load decreases capacity.

P0 VERTICAL ANGLE PLATE

(Weight: 3.75 lb.)

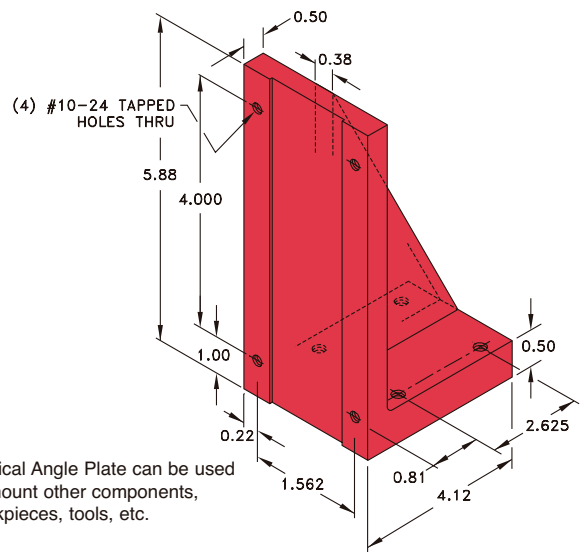

- Vertical Angle Plate can be used to mount other components, workpieces, tools, etc.

M Series: Type M1

4"

M1 HAND FEED

(Single Axis • Weight: 16 lb. • Feedscrew 5/8-10)

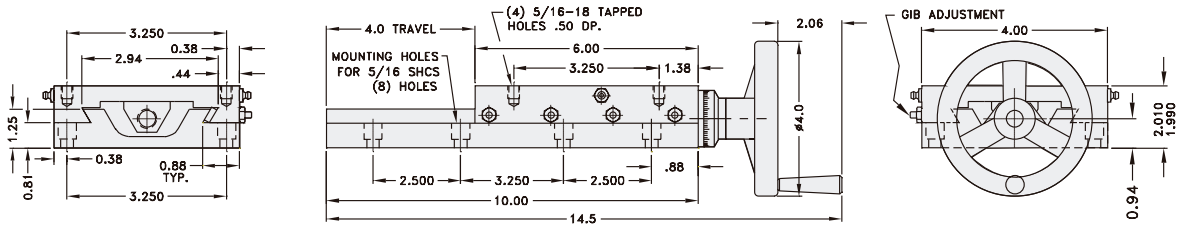

M11 COMPOUND HAND FEED

(2-Axis • Weight: 32 lb.)

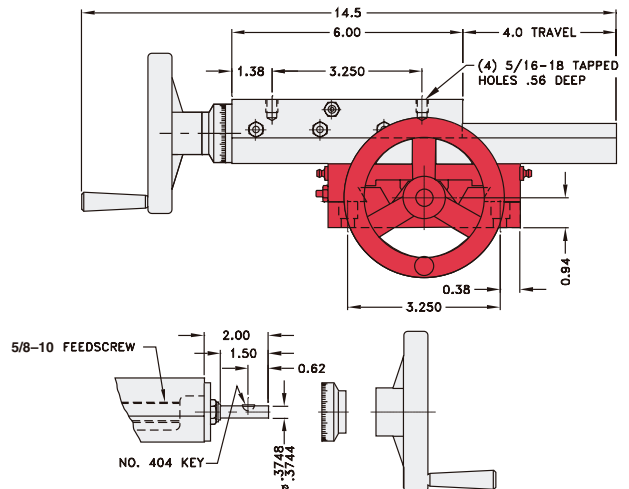
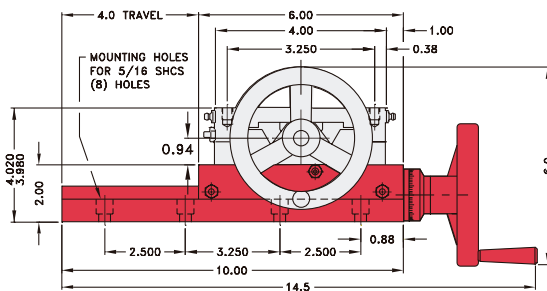

- Torque required to turn M1 feedscrew is about 15 in/lb.
- When the slide is mounted to a sidewall with its feedscrew at right angles to the vertical plane, the gib must be on the bottom. (See Slide Mounting Attitude, page 48.)
- For load capacities, see Slide Load Capacity chart, page 50.
- Slides can be supplied without a micrometer handwheel, allowing use of a ratchet handle, crank or other device.

M1P VERTICAL ANGLE PLATE WITH HAND FEED

(Single Axis • Weight: 36 lb.)

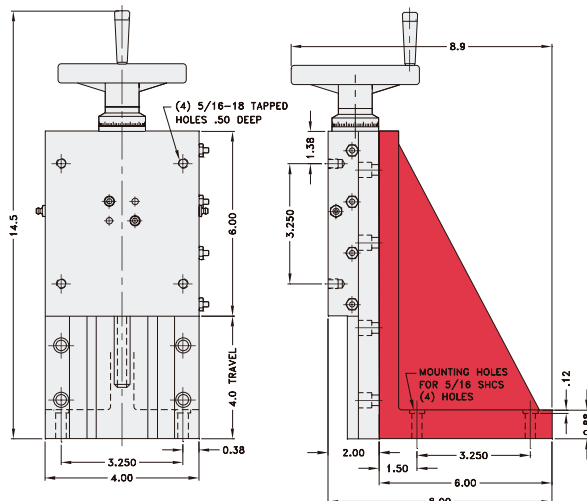

- Load capacity is measured at the saddle; overhanging load decreases capacity.

*A slide stop washer is provided on this vertical slide model.

P1 VERTICAL ANGLE PLATE

(Weight: 20 lb.)

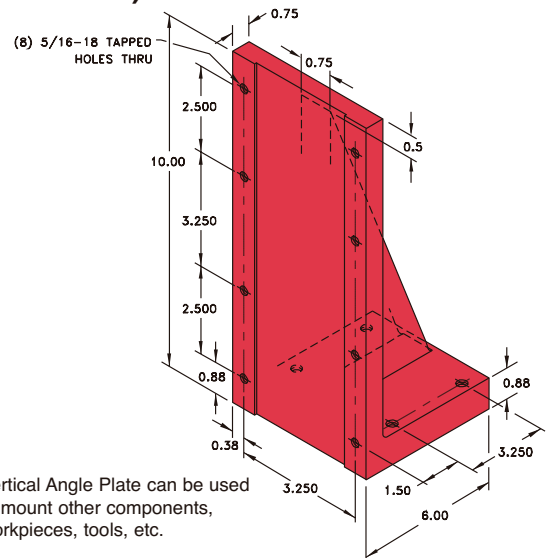

- Vertical Angle Plate can be used to mount other components, workpieces, tools, etc.

M Series: Type M2

6"

M2 HAND FEED

(Single Axis • Weight: 26 lb. • Feedscrew 5/8-10)

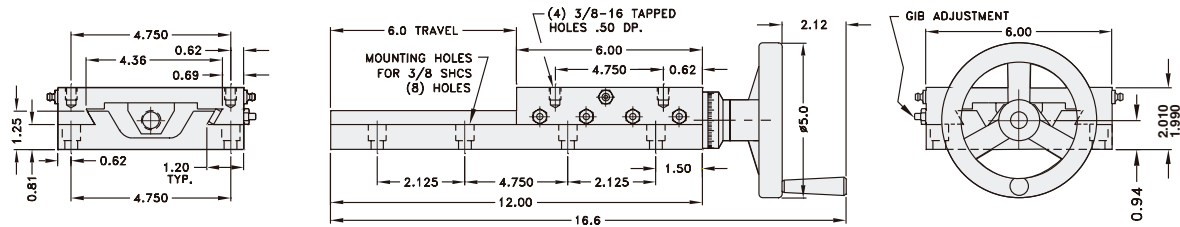

M22 COMPOUND HAND FEED

(2-Axis • Weight: 52 lb.)

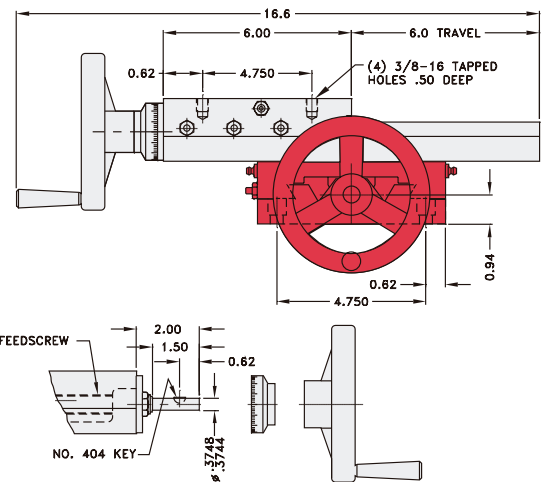
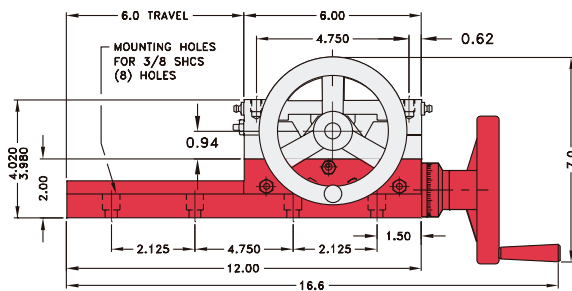

- Torque required to turn M2 feedscrew is about 17 in/lb.
- When the slide is mounted to a sidewall with its feedscrew at right angles to the vertical plane, the gib must be on the bottom. (See Slide Mounting Attitude, page 48.)
- For load capacities, see Slide Load Capacity chart, page 50.
- Slides can be supplied without a micrometer handwheel, allowing use of a ratchet handle, crank or other device.

M2P VERTICAL ANGLE PLATE WITH HAND FEED

(Single Axis • Weight: 64 lb.)

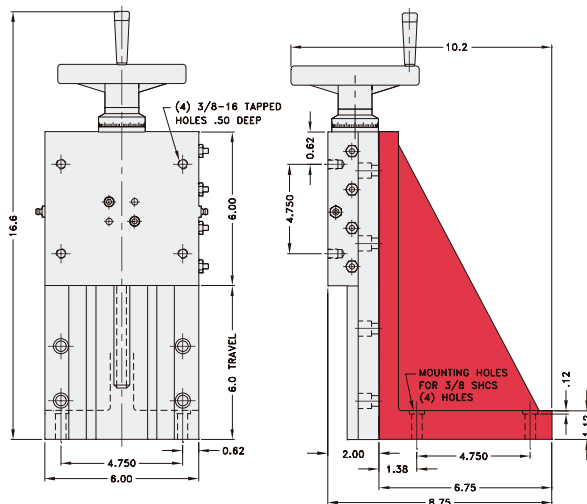

- Load capacity is measured at the saddle; overhanging load decreases capacity.

*A slide stop washer is provided on this vertical slide model.

P2 VERTICAL ANGLE PLATE

(Weight: 38 lb.)

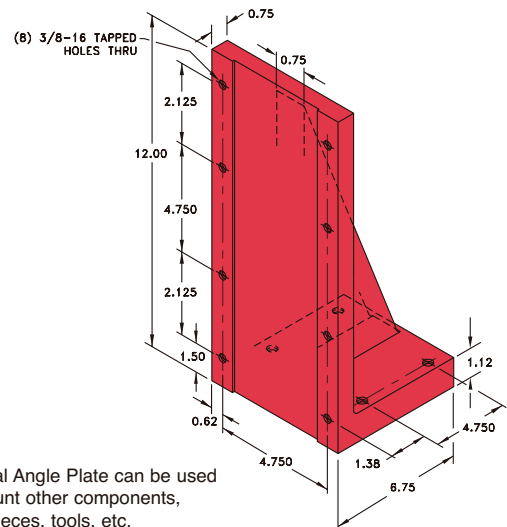

- Vertical Angle Plate can be used to mount other components, workpieces, tools, etc.

M Series: Type M3

8"

M3 HAND FEED

(Single Axis • Weight: 66 lb. • Feedscrew 3/4-10)

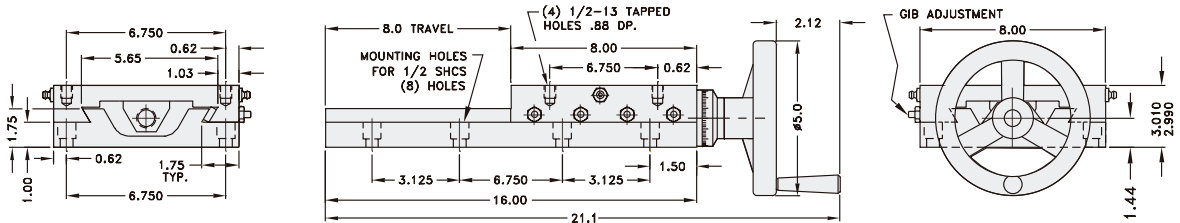

M33 COMPOUND HAND FEED

(2-Axis • Weight: 132 lb.)

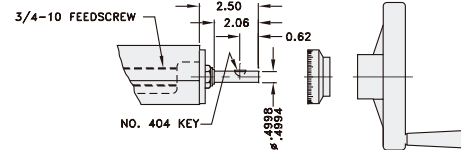
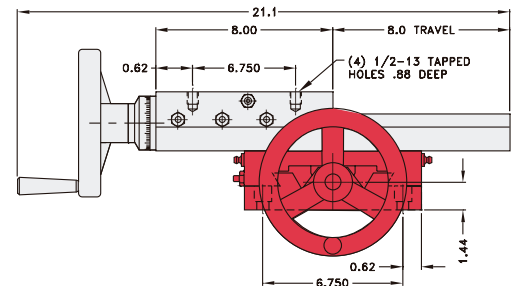
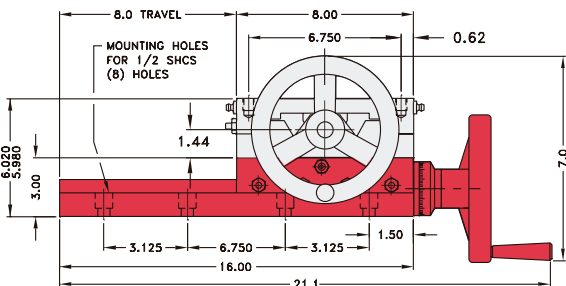

- Torque required to turn M3 feedscrew is about 20 in/lb.
- When the slide is mounted to a sidewall with its feedscrew at right angles to the vertical plane, the gib must be on the bottom. (See Slide Mounting Attitude, page 48.)
- For load capacities, see Slide Load Capacity chart, page 50.
- Slides can be supplied without a micrometer handwheel, allowing use of a ratchet handle, crank or other device.

M3P VERTICAL ANGLE PLATE WITH HAND FEED

(Single Axis • Weight: 128 lb.)

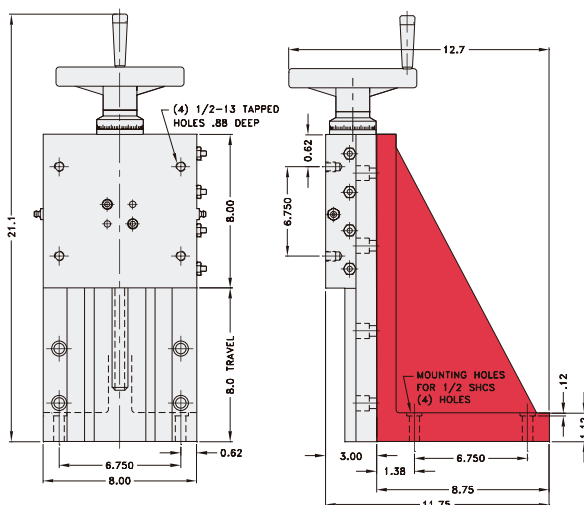

- Load capacity is measured at the saddle; overhanging load decreases capacity.

P3 VERTICAL ANGLE PLATE

(Weight: 62 lb.)

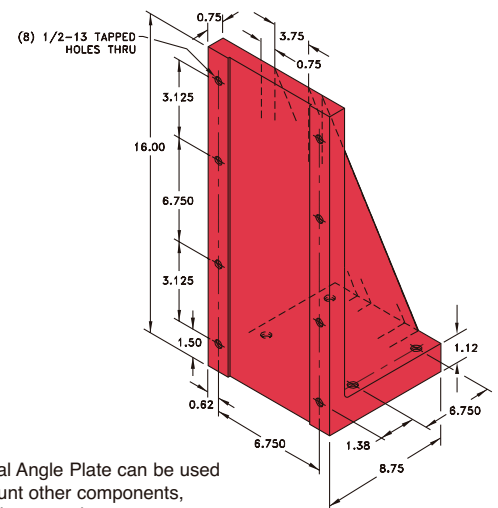

- Vertical Angle Plate can be used to mount other components, workpieces, tools, etc.

*A slide stop washer is provided on this vertical slide model.

M Series: Type M4

10"

M4 HAND FEED

(Single Axis • Weight: 145 lb. • Feedscrew 1-10)

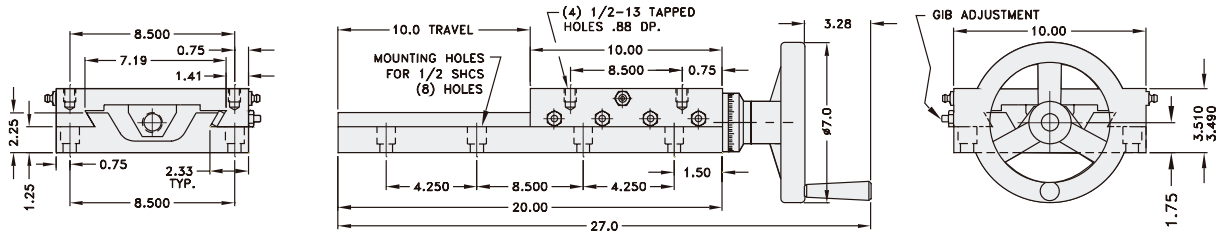

M44 COMPOUND HAND FEED

(2-Axis • Weight: 290 lb.)

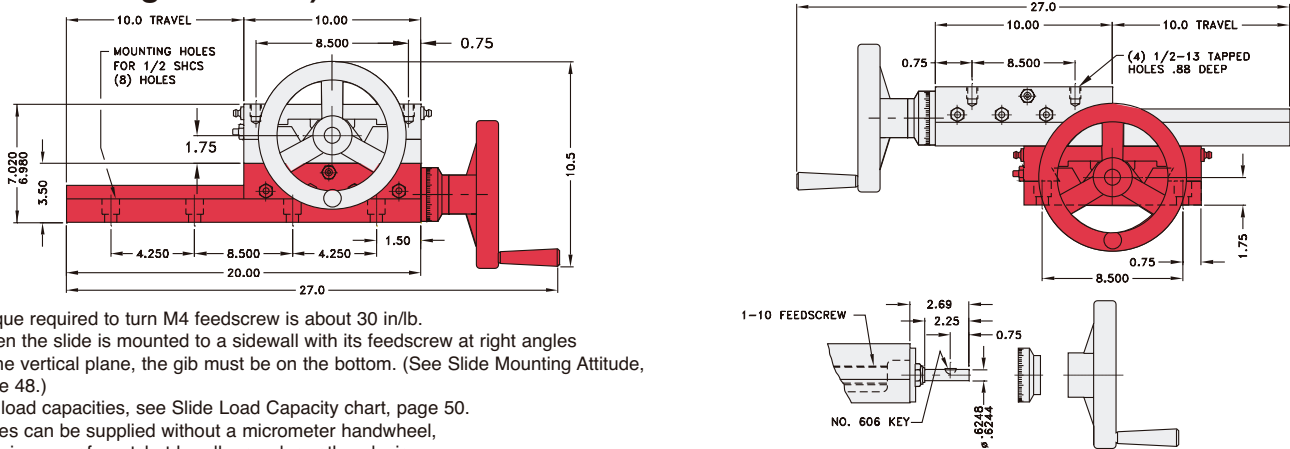

- Torque required to turn M4 feedscrew is about 30 in/lb.
- When the slide is mounted to a sidewall with its feedscrew at right angles to the vertical plane, the gib must be on the bottom. (See Slide Mounting Attitude, page 48.)
- For load capacities, see Slide Load Capacity chart, page 50.
- Slides can be supplied without a micrometer handwheel, allowing use of a ratchet handle, crank or other device.

M4P VERTICAL ANGLE PLATE WITH HAND FEED

(Single Axis • Weight: 265 lb.)

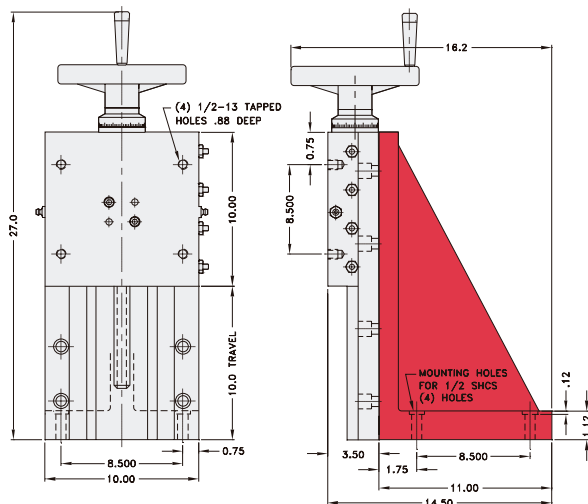

- Load capacity is measured at the saddle; overhanging load decreases capacity.

*A slide stop washer is provided on this vertical slide model.

P4 VERTICAL ANGLE PLATE

(Weight: 120 lb.)

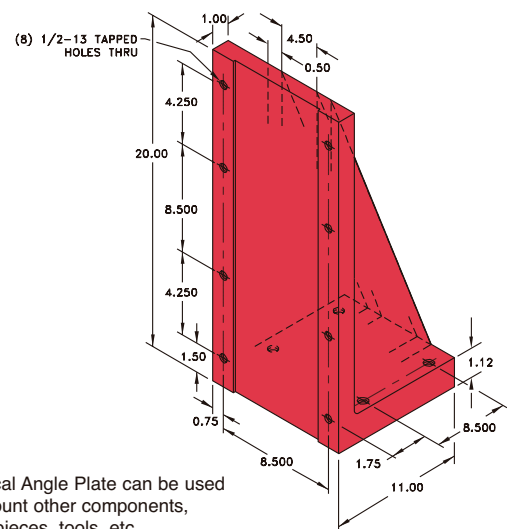

- Vertical Angle Plate can be used to mount other components, workpieces, tools, etc.

ACCORDION WAY COVERS*

(Model Code: B)

Made of hypolon polyester, the optional Accordion Way Covers shield the slide way surfaces, feed mechanisms and slide cavity from abrasive material, coolant and dust. These covers are available for all M Series slides, except Type M0.

When Accordion Way Covers are provided, the slide travel length is reduced due to the bellows stack-up at each end. As the drawing below illustrates, the Accordion Way Covers will extend beyond the sides of the slide (OW dimension) – but not above the top of the saddle.

See chart below for the actual travel available on each M Series slide when equipped with Accordion Way Covers.

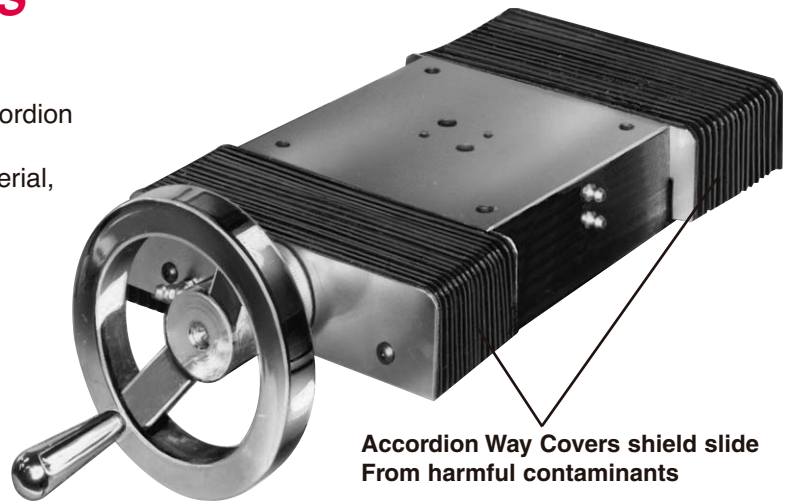

SLIDE MODEL CODE

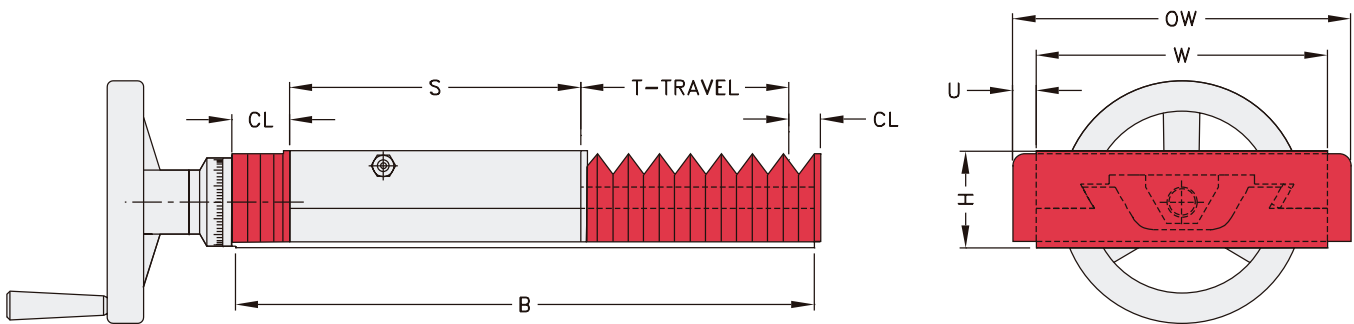
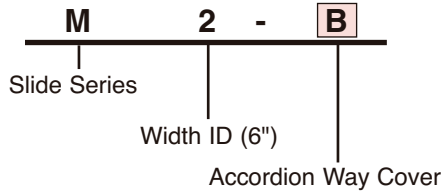

MODEL	DIMENSIONS IN INCHES							
	B	CL	H	OW	S	T	U	W
M0	N/A	N/A	N/A	N/A	N/A	N/A	N/A	N/A
M1-B	10.00	0.75	2.00	5.06	6.00	2.50	0.53	4.00
M2-B	12.00	1.03	2.00	7.12	6.00	3.94	0.56	6.00
M3-B	16.00	0.81	3.00	10.00	8.00	6.38	1.00	8.00
M4-B	20.00	1.00	3.50	12.12	10.00	8.00	1.06	10.00

* Consult MASTER/SETCO Solution Team for special covers when contaminants are sharp or heavy in nature.

RIGHT ANGLE HAND FEED

(Model Code: M-Series = R DS-Super Select = RAF)

The optional Right Angle Hand Feed attachment is used when mounting space at the end of a slide is limited and better access is an important consideration. This heavy duty assembly can be mounted in any one of four 90° positions. When placing your order, specify the desired mounting position from the following:

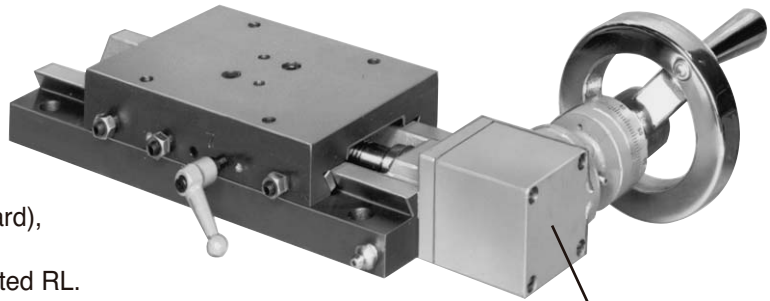

Standard Right Angle Hand Feed Position

- Handwheel to the right of the feedscrew (standard), designated RR.
- Handwheel to the left of the feedscrew, designated RL.
- Handwheel mounted up to the feedscrew, designated RU.
- Handwheel mounted down to the feedscrew, designated RD.

The chart below illustrates the Right Angle Hand Feed attachment available for the M Series 4" through 10" slides.

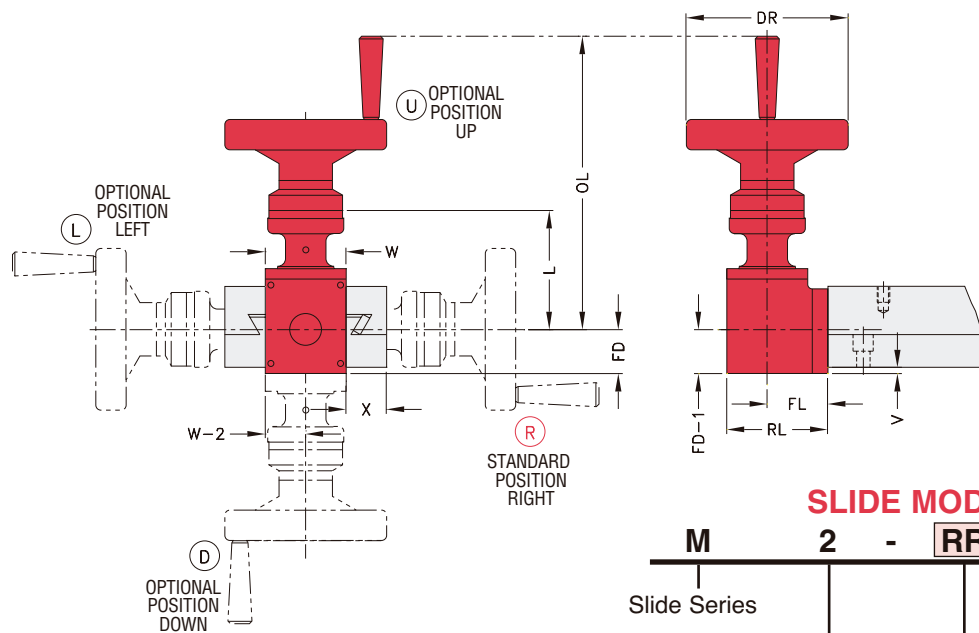

SLIDE MODEL CODE

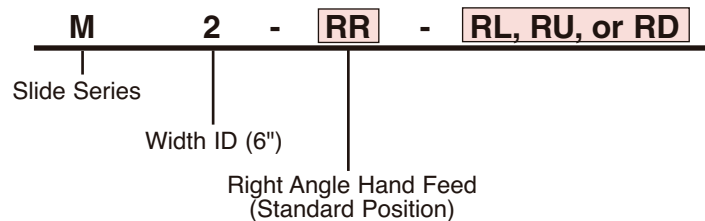

MODEL	DIMENSIONS IN INCHES										
	DR	FD	FD-1	FL	L	OL	RL	V	W	W-2	X
M0	N/A	N/A	N/A	N/A	N/A	N/A	N/A	N/A	N/A	N/A	N/A
M1-R□	4.0	0.94	1.00	1.50	2.94	7.2	2.50	0.06	2.00	1.00	1.0
M2-R□	5.0	0.94	1.00	1.50	2.94	7.4	2.50	0.06	2.00	1.00	2.0
M3-R□	5.0	1.44	2.00	2.44	5.19	9.9	4.31	0.56	4.00	2.00	2.0
M4-R□	7.0	1.75	2.00	2.44	5.38	12.0	4.31	0.25	4.00	2.00	3.0

□ = R U (up), L (left), D (down), or R (right)

WAY WIPERS

(Model Code: W)

Optional Way Wipers are mounted to the ends of the saddle to wipe chips, dirt and coolant from way surfaces as the saddle traverses along the base. The neoprene wiper material that fits snugly against the base does the cleaning. This material is held securely to the saddle by metal mounting plates.

It is not recommended that Way Wipers travel beyond the end of the base since the wiper could pull dirt back onto the base when the saddle is retracted. Way Wipers reduce usable slide travel by about 0.5".

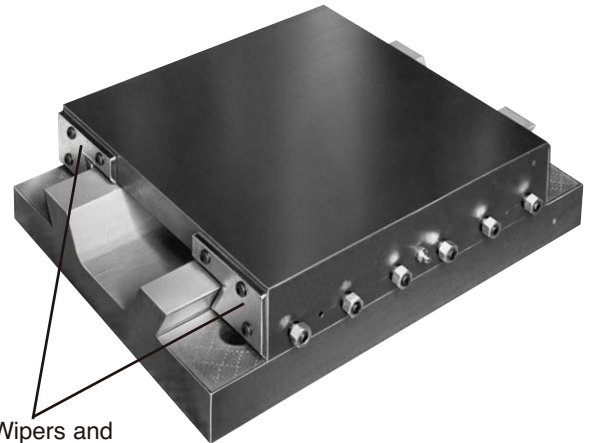

Way Wipers and Mounting Plates

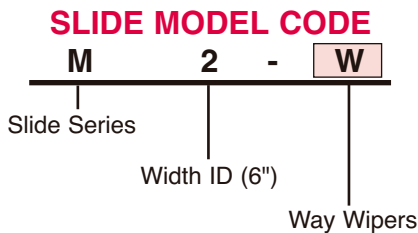

CRANK OR RATCHET HANDLE

(Model Code: RH)

For ease in moving heavy duty slides, or where there are interferences, substitute the optional Crank or Ratchet Handle for the standard handwheel. Optional handles are available on all M Series slides, except the Type M0. They can also be provided on the Right Angle Hand Feed Attachment (page 42).

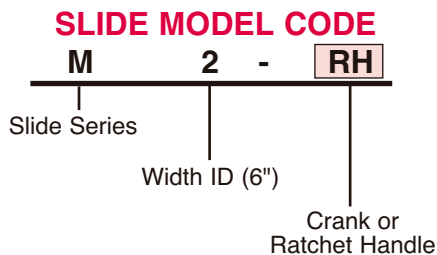
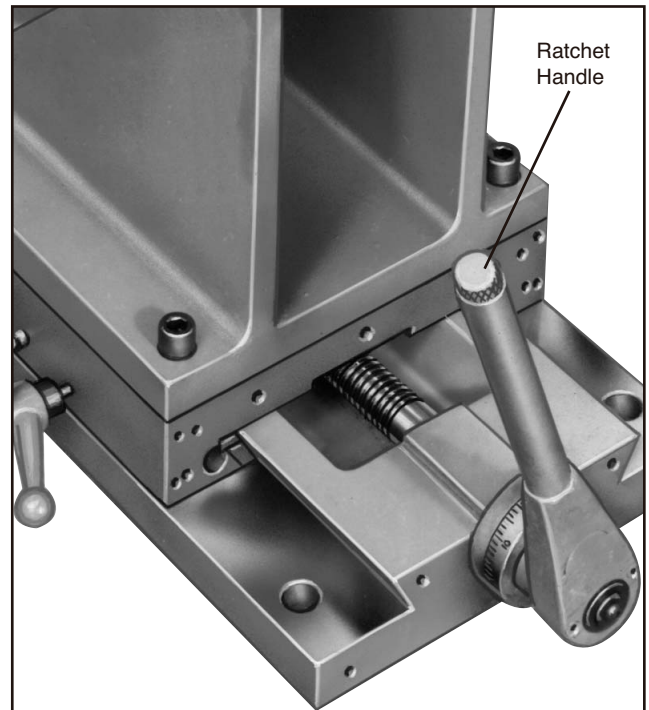

SQUARE 360° SWIVEL

(Model Code: SS)

The optional Square Swivel attachment is available to provide 360° rotation of your slide assembly. The top plate rotates on a hardened center pivot while four T-bolts ride in the circular T-slot located in the base. Locking nuts, easily accessed from four sides, hold the Square Swivel in the angular position your application requires.

The swivel is equipped with a circular scale that is calibrated in degree increments. Holes for mounting the swivel are machined in the base. The load capacity of the swivel is equal to the comparable size dovetail slide. See chart below.

Note: Consult factory when mounting Square Swivel in any position other than horizontal.

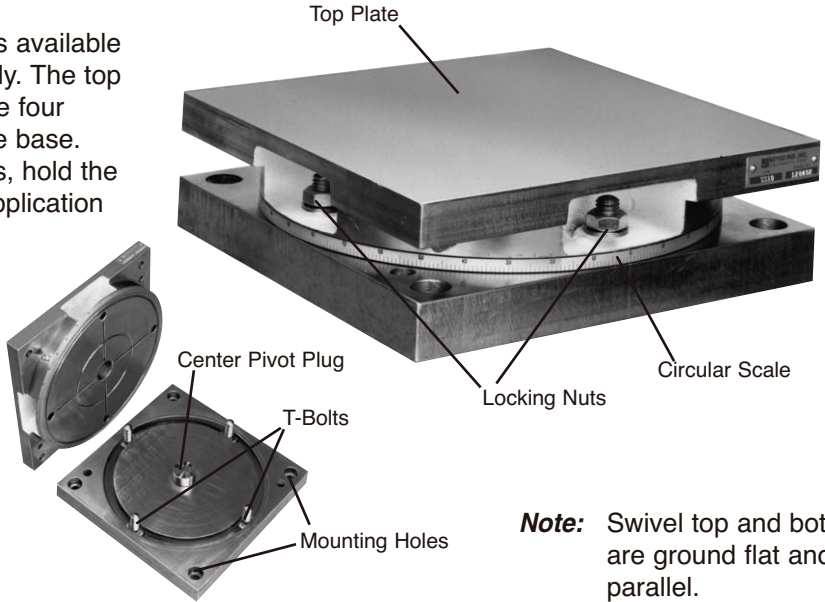

Note: Swivel top and bottom are ground flat and parallel.

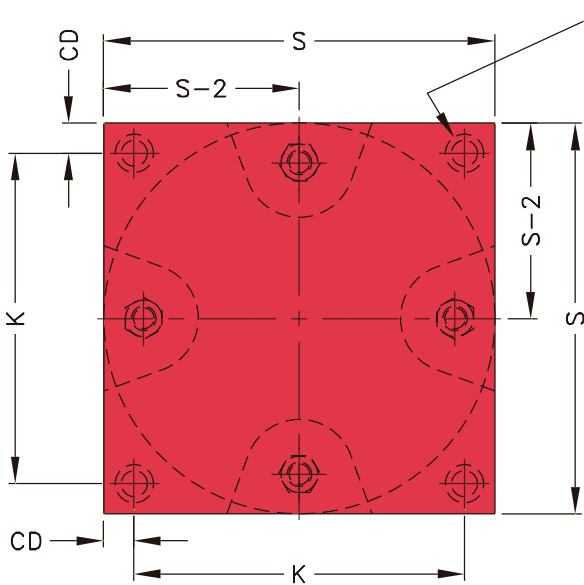

(4) HOLES FOR E SHCS

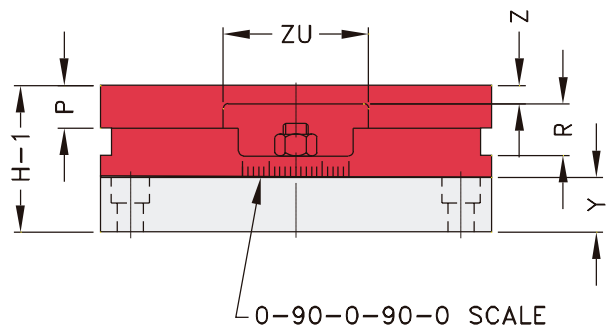

TYPE	DIMENSIONS IN INCHES											Weight (Lb.)
	CD	E	H-1	K	P	R	S	S-2	Y	Z	ZU	
SS4	0.38	5/16	2.31	3.250	0.69	0.75	4.00	2.00	0.88	0.31	2.00	8.0
SS6	0.62	3/8	2.50	4.750	0.69	0.81	6.00	3.00	1.00	0.25	2.25	18.0
SS8	0.62	1/2	3.00	6.750	0.88	1.06	8.00	4.00	1.12	0.38	2.88	40.0
SS10	0.75	1/2	3.00	8.500	0.88	1.06	10.00	5.00	1.12	0.38	3.25	65.0

MANUAL SADDLE LOCKS

(Model Code: L)

The optional Manual Locks make it easy to hold the slide in any desired position along the length of the base. Single or Dual Locks can be provided. One lock is normal for Type M3 and smaller slides; two locks are supplied for the larger Type M4.

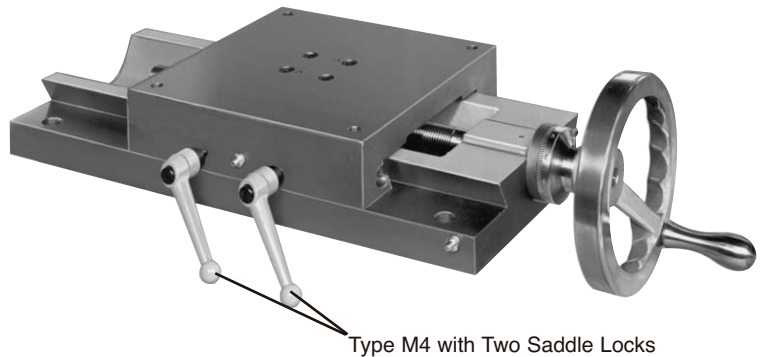

Type M4 with Two Saddle Locks

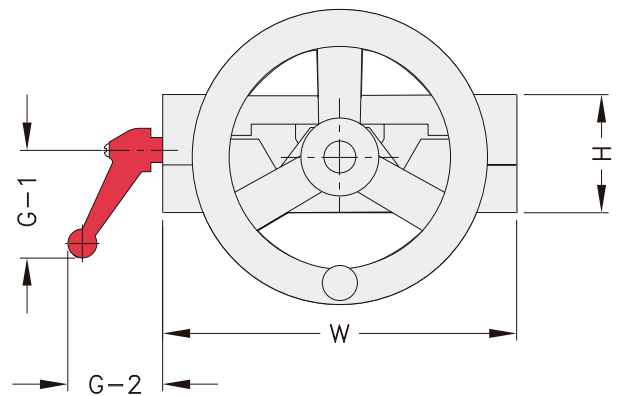
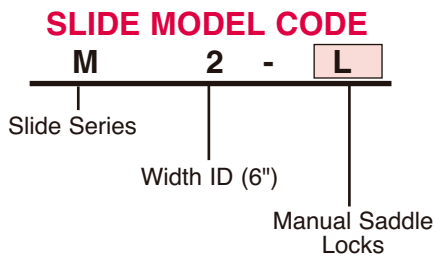
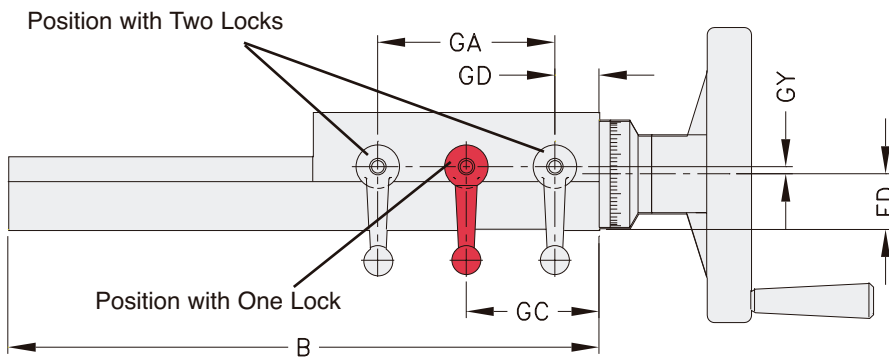

MODEL	DIMENSIONS IN INCHES									
	B	FD	GA	GC	GD	GY	G-1	G2	H	W
M0-L	6.00	0.46	—	2.00	—	0.03	1.6	1.5	1.00	2.00
M1-L	10.00	0.94	—	2.25	—	0.1	1.6	1.5	2.00	4.00
M2-L	12.00	0.94	—	2.25	—	0.1	1.6	1.5	2.00	6.00
M3-L	16.00	1.44	—	4.00	—	0.1	2.5	2.2	3.00	8.00
M4-L	20.00	1.75	3.25	—	3.40	0.1	3.1	2.8	3.50	10.00

INTRODUCTION

SETCO's motion experts can provide assistance with linear and rotary movement applications.

Once we know your manufacturing demands, we can recommend the slide or spindle combination that meets all of your needs. This one-stop solution eliminates your concerns with source responsibility.

Shown here are a variety of solutions for a variety of industries, including aerospace, defense, automotive, agriculture, off-road and trucking.

M0 Single Feed with Micrometer Dial.

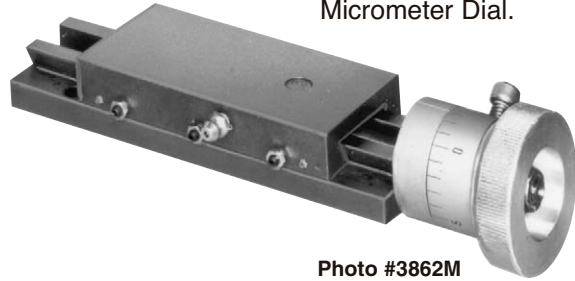

Photo #3862M

M3P Angle Plate Slide with Hand Feed and Accordion Way Covers.



Photo #3866M

M33 Compound Slide with Hand Feed and Accordion Way Covers.

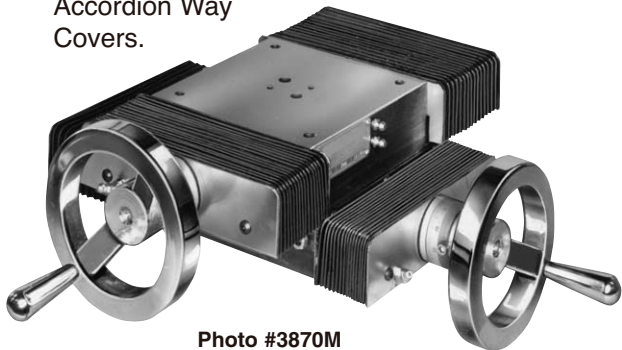

Photo #3870M

M11 Compound Slide with Hand Feed.

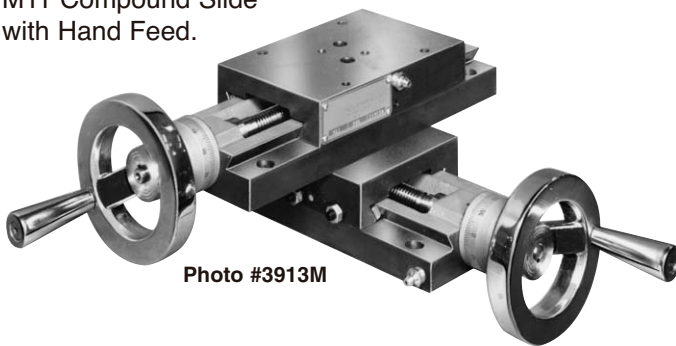

Photo #3913M

Type 6101-36G/M2L Standard Size 5 Grinding Spindle with feet milled to flush mount on an M2L (6" wide) Dovetail Slide with saddle lock.



Photo #3995M

M Series

Application Photos

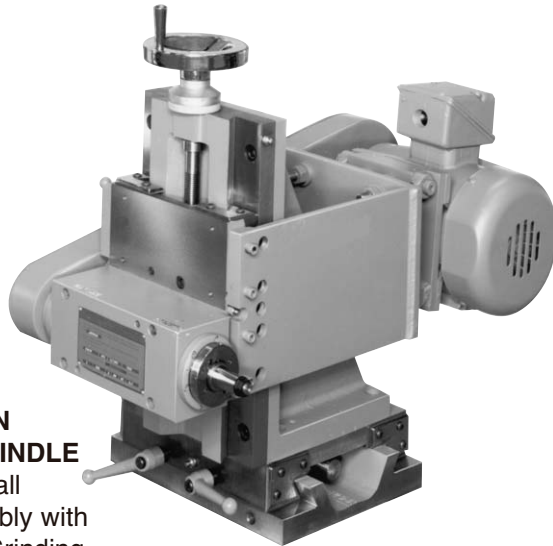

**COMBINATION
SLIDE and SPINDLE**
Special Rise/Fall
Spindle Assembly with
a Belt Driven Grinding
Spindle and special bracket
drive package mounted on
M4 Dovetail Slide.

Photo #3931M

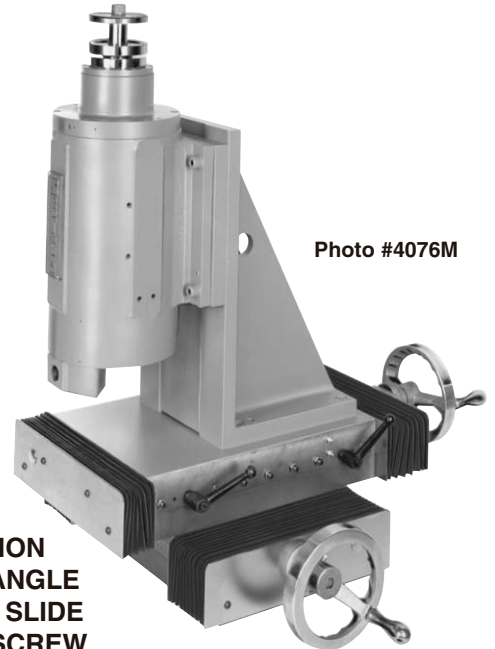

Photo #4076M

**COMBINATION
SPINDLE, ANGLE
PLATE and SLIDE
with BALLSCREW**

Motorized grinding spindle riser mounted on Type P3
Angle Plate. Mounted on Type M4 Slide Assembly
with Accordion Way Covers and two Saddle Locks -
all mounted to Type M4 Slide Assembly with
Accordion Way Covers and Saddle Locks.



Photo #2539M

Type 2705-36G
Surface Grinding Spindle
with mounted bracket, wheel
holder and mounted on a dovetail
slide with right angle hand feed.

Special Motorized
spindle and dovetail
slide assembly
complete with fixture
slide and riser
assembly.

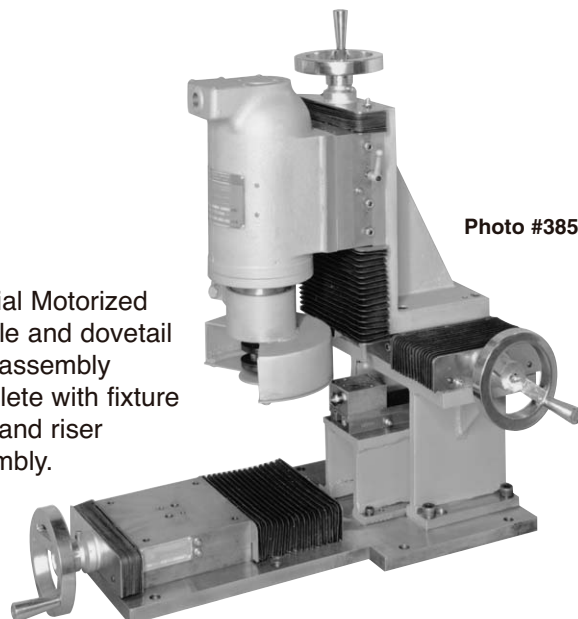

Photo #3853M

Design Data

Slide Tolerances

- Flatness of base bottom - 0.001" per 12".
- Flatness of saddle top - 0.001" per 12".
- Parallelism of saddle top to base bottom - 0.001" per 12".
- Parallelism of reference edge (on side base) to dovetail way - 0.001" per 12".
- Slide overall height tolerance - nominal to +/- 0.010".
- Perpendicularity of base ends to base bottom and base reference edge - 0.001".
- Perpendicularity of saddle ends to saddle top and saddle reference edge - 0.003".
- Squareness in each plane of compound slide - 0.001" per 12" cumulative from axis to axis.

Slide Tracking Accuracy

All Master Dovetail Slides have a guaranteed straightness of travel (side to side and up and down) not to exceed 0.0005" per 12", with an accumulation not to exceed 0.00025" for each additional 12" of travel.

Slide Mounting Attitude

Master Dovetail Slides can be mounted at any attitude, with the most common illustrated at right. The mounting attitude affects power requirements as well as lubrication grooves and porting. Specify slide mounting attitude on all applications.

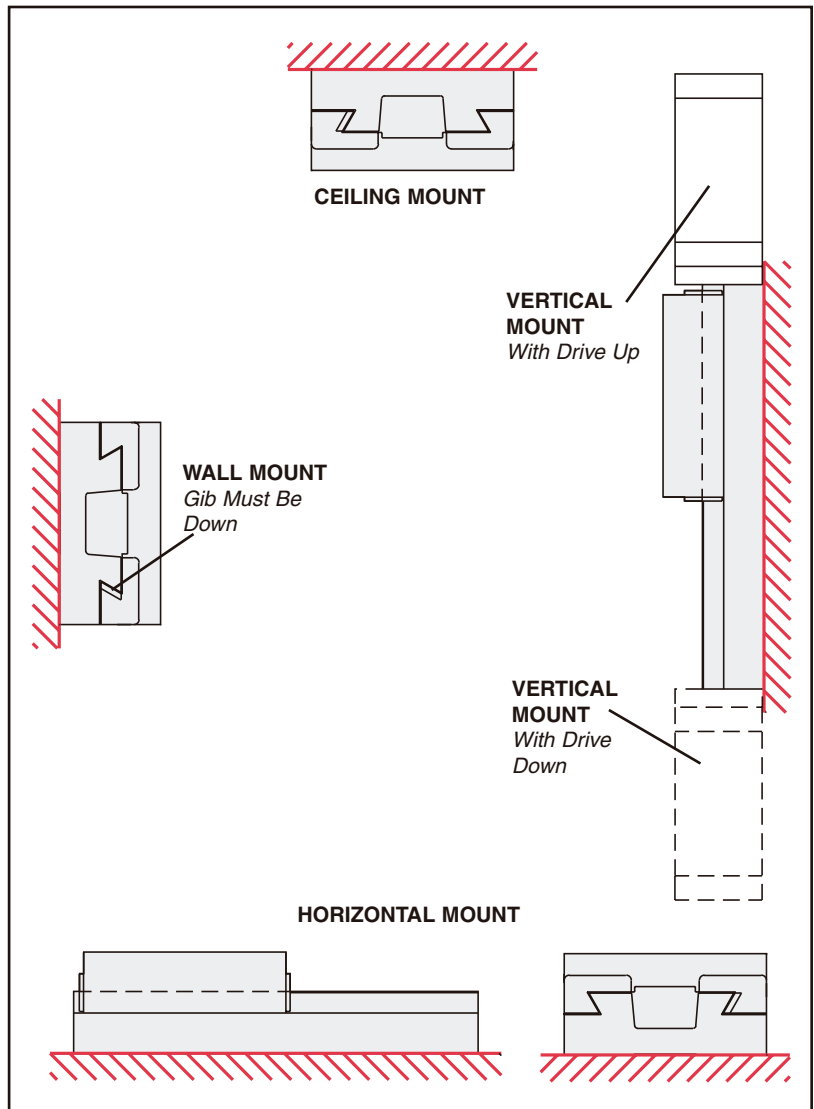
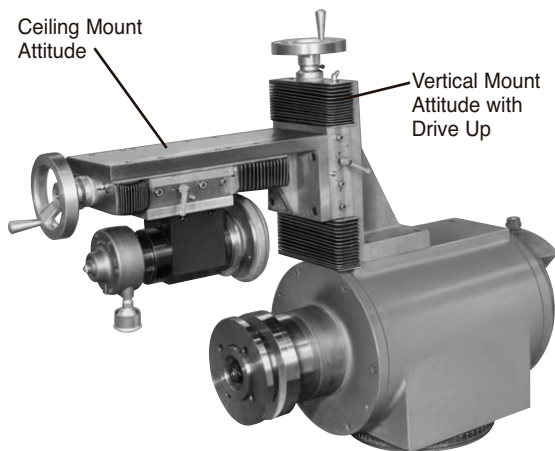

Design Data

Force and Torque Requirements

The torque required to power the slide consists of the torque needed to overcome friction, all external loading and miscellaneous factors.

Note: Below torque calculation does not take into consideration acceleration/deceleration requirements. Consult factory for these applications.

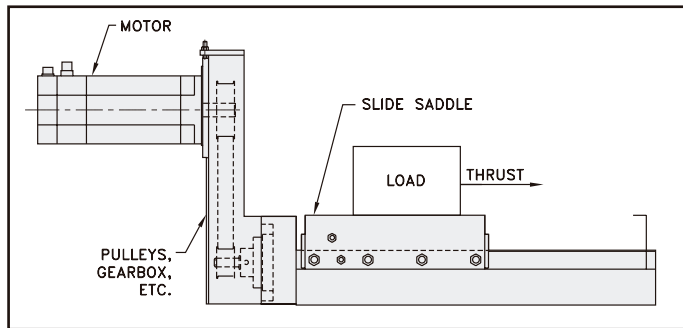

Torque Calculations:

$$T_{motor} = \frac{TB1}{G.R. \times e_2} \quad \text{or} \quad \frac{TB2}{G.R. \times e_2}$$

Ballscrew Formula

$$TB1 = \frac{W \times \mu \times L}{6.28 \times e_1} + \frac{T \times L}{6.28 \times e_1} + \frac{T \times \mu \times L}{6.28 \times e_1} + T_m$$

(1) (2) (3) (4)

Acme Screw Formula

$$TB2 = \left[\frac{W \times \mu \times D + T \times D}{2} \right] \left[\frac{L \times 1.29 \times D}{3.14 \times D - 0.4 \times L} \right] + T_m$$

Definitions

Force and Torque Requirements

- e** = Efficiency
 e_1 of ballnut is typically 90%
 e_2 of gearbox, pulleys, etc., is typically 95%
- G.R.** = Ratio of motor speed to ballscrew speed
- L** = Lead movement of slide in inches per revolution of ballscrew (inch)
- TB1** = Torque at ballscrew (in-lb)
- TB2** = Torque at Acme screw (in-lb)
- T** = Thrust force applied by slide/load on a workpiece (lb)
- Tm** = Miscellaneous torque
- Tmotor** = Load torque required at motor (in-lb)
- μ** = Coefficient of friction (See page 50)
Note: Use $m = 1.0$ for all vertical applications.
- W** = Weight of the saddle and load (lb)
- D** = Diameter of Acme feedscrew
 - (1) Friction torque generated by weight of the slide.
 - (2) Torque required for thrust loading.
 - (3) Friction torque generated by the thrust load (approximation).
 - (4) Torque required to overcome seals, gib adjustments, etc. (10% of TB or 10 in-lb minimum.)

Thrust Capacities

The maximum thrust capacity for the various feedscrew and ballscrew drive packages available is shown in the chart at right. For proper selection of slide sizing and saddle lengths, the thrust capacity of the drive package being considered must be compared to the load capacity (Mz) of the slide. (See page 50.)

- Notes:**
1. The values shown in the chart are based on the mechanical thrust limitations of the drive package.
 2. For extremely long travel applications, consult factory for limitations due to column loading.
 3. For static applications, consult factory for limitations due to saddle locking device and/or back-driving force.

MODEL	TYPE OF SCREW					
	FS (lb.)		FSI (lb.)		FGM (lb.)	
	STATIC	DYNAMIC	STATIC	DYNAMIC	STATIC	DYNAMIC
M0	1630	1010	N/A	N/A	N/A	N/A
M1	1920	1190	N/A	N/A	N/A	N/A
M2	1920	1190	N/A	N/A	N/A	N/A
M3	3190	1690	N/A	N/A	N/A	N/A
M4	3830	1880	N/A	N/A	N/A	N/A
DS4	N/A	N/A	1920	1190	N/A	N/A
DS6	N/A	N/A	1920	1190	12,000	1550
DS8	N/A	N/A	3830	1880	12,000	1550
DS10	N/A	N/A	3830	1880	12,000	1360
DS12	N/A	N/A	3830	1880	12,000	1360
DS16	N/A	N/A	8140	3080	37,000	4700

Design Data

Slide Load Capacity

To optimize slide operation over the long haul, one of the most important considerations in selection is the loading applied to the slide. Loading capacity is based on the pressure exerted by an externally applied load on the engaged slide way surfaces. These externally applied loads are considered to be the following:

- **STATIC** Loading - External loading is applied to a stationary saddle.
- **DYNAMIC** Loading - External loading is applied to a moving saddle.
- **SINGLE** Loading - Only one external loading is applied.
- **COMBINED** Loading - More than one external loading is applied.

The recommended maximum load and moment capacities can be determined from the "Slide Load Capacity Chart." Use the data only as a guide to determine the proper size slide for a particular application. The values in the chart are based on a way surface bearing pressure of 25 psi. However, this pressure may be adjusted to suit your application using the following guidelines:

- **Use 25 psi for -**
 - Manual feed slides.
 - Manual grease lubricated slides.
 - Slides used for precision machining and grinding applications.
 - Slides subjected to combined loading.
- **Use 50 psi (multiply values in chart by 2) for -**
 - Power feed slides.
 - Slides having low friction material.
 - Slides having forced lubrication.
 - Slides used for rough machining and positioning applications.
 - Slides subjected to single loading.
- **Use 500 psi (multiply values in table by 20) for -**
 - Slides subjected to static loading.

Coefficient of Friction

- 0.30 standard.
- 0.15 with forced lubrication.
- 0.10 with Low-Friction Way Bearing Material and no lubrication.
- 0.05 with Low-Friction Way Bearing Material and forced lubrication.

Slide Load Capacity Chart

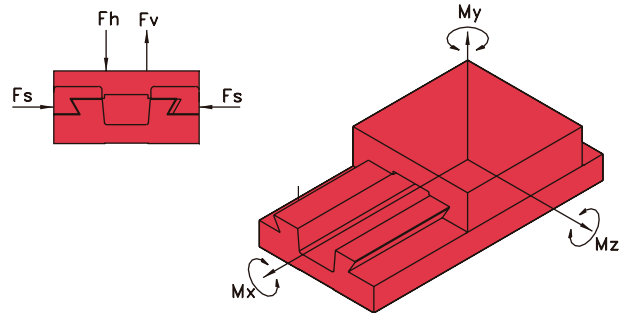

Data based on calculations at 25 psi:

MODEL	Fh (Lb.)	Fv (Lb.)	Fs (Lb.)	Mx* (Lb.)	My* (Lb.)	Mz* (Lb.)
M0	115	60	50	25	35	90
M1	265	75	65	105	100	180
M2	360	75	65	165	100	180
M3	705	175	150	485	300	575
M4	1165	290	250	980	625	1440
DS4	35 x S	16 X S	15 X S	25 X S	3.50 X S ²	6 X S ²
DS6	55 x S	22 X S	20 X S	50 X S	4.80 X S ²	8 X S ²
DS8	80 x S	22 X S	20 X S	65 X S	4.80 X S ²	9 X S ²
DS10	90 x S	30 X S	30 X S	115 X S	6.60 X S ²	11 X S ²
DS12	120 X S	30 X S	30 X S	130 X S	6.60 X S ²	12 X S ²
DS16	160 X S	45 X S	45 X S	260 X S	9.70 X S ²	17 X S ²

* See Notes 1 and 2, page 51.

Load Cases and Equations

<p>Slide Loading = F Slide Capacity = Fh Fh > F</p> <p>LOAD CASE I</p>	<p>Slide Loading = F x d Slide Capacity = Mx Mx > F x d</p> <p>LOAD CASE IV</p>
<p>Slide Loading = F Slide Capacity = Fv Fv > F</p> <p>LOAD CASE II</p>	<p>Slide Loading = F x d Slide Capacity = Mz Mz > F x d</p> <p>LOAD CASE V</p>
<p>Slide Loading = F Slide Capacity = Fs Fs > F</p> <p>LOAD CASE III</p>	<p>Slide Loading = F x d Slide Capacity = My My > F x d</p> <p>LOAD CASE VI</p>

Design Data

Definitions

Slide Load Capacity

d	= Perpendicular distance (inches) from saddle to applied load
F_h	= Applied load (lb.) perpendicular and into plane of saddle top
F_v	= Applied load (lb.) perpendicular and away from plane of saddle top
F	= Applied external load (lb.)
F_s	= Applied load perpendicular and into or away from plane of saddle side (lb)
M_x	= Moment about the saddle width (in-lb.)
M_y	= Moment about plane of saddle top (in-lb.)
M_z	= Moment about saddle length (in-lb.)

Notes: 1. For applications where load is applied in the direction of slide travel, the slide load capacity may be limited to the capacity of the slide feed mechanism. Check the load values with the maximum thrust capacities for the feed mechanism being used.

For static applications, the slide load capacity may be limited by the saddle locking device.

Slide load capacity is based on uniformly applied loads and moments. Consult factory on all applications where shock loading is present.

2. For applications involving an M_x moment, the slide load capacity may be limited by the F_s Load capacity.

Combined Load Case

Here's an example illustrating combined loading—a slide subjected to two dynamic loads. A 600 lb. boring spindle is mounted to a horizontal slide and will be subjected to a 500 lb. thrust load. Two calculations must be performed: one to determine the necessary saddle length based on the weight of the spindle; a second based on the thrust load. Whichever calculation yields the greater saddle length, this is the number that must be used.

In cases where both calculations suggest a saddle length less than the width of the slide, then either a smaller width slide can be used or the saddle length must be increased to a minimum length (i.e., the saddle length cannot be shorter than the width of the slide).

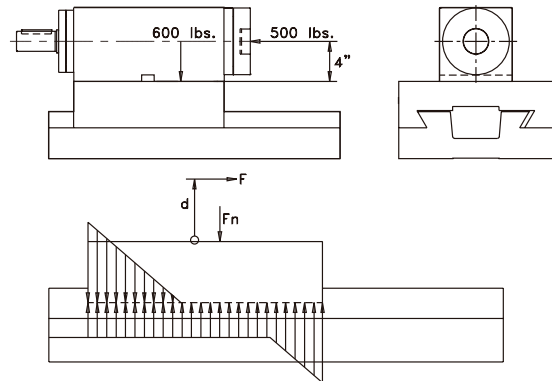

DYNAMIC Loading - moving weight of spindle

$$\begin{aligned} \text{Load Case} &= 1 \\ \text{Combined Loading} &= 25 \text{ psi} \\ \text{Loading } F &= 600 \text{ lb} \end{aligned}$$

$$\text{Equation: } F_h > F$$

$$F_h > 600 \text{ lb}$$

Considering a DS12 Dovetail Slide

$$\text{Load Capacity (25 psi), } F_h = 120 \times S$$

$$120 \times S = 600$$

$$S = 5''$$

DYNAMIC Loading - feeding boring spindle

$$\begin{aligned} \text{Load Case} &= V \\ \text{Combined Loading} &= 25 \text{ psi} \\ \text{Loading} &= F \times d \\ &= 500 (4) \\ &= 2000 \text{ in-lb} \end{aligned}$$

$$\text{Equation: } M_z > F \times d$$

$$M_z > 2000 \text{ in-lb}$$

$$\text{Load Capacity (25 psi), } M_z = 12 \times S^2$$

$$12 \times S^2 = 2000$$

$$S = 13''$$

Use a DS12 Slide with 13" long saddle.

YOUR SINGLE SOURCE

For Repair, Rebuild, Exchange, New – Plus a Total Range of Related Services to Enhance Your Just-In-Time Manufacturing

PRODUCTS



Dovetail Slides



Linear Recirculating Bearing Slides

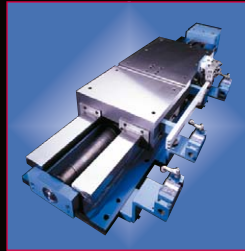

Hardened Steel Way Slides



Grinding Spindles and Accessories

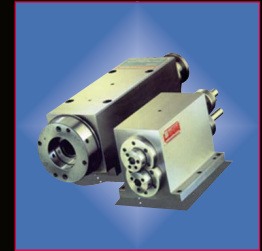

Boring and Milling Spindles



Sentry Belt-Driven Spindles

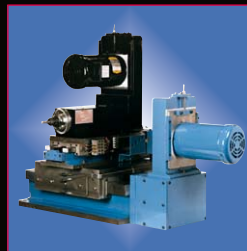

Spindle/Slide Combinations



3-Axis Machining Modules



ProMetrix Belt-Driven Spindles



Smart Closed-Loop Motorized Spindles

SERVICES



Total Solution Team Engineering



Field Service and Vibration Analysis



State-of-the-Art Slide Repair



Leading Edge Spindle Repair



Complete In-House Manufacturing, Assembly



Hands-On Spindle and Slide Repair Training

MASTER SETCO

5880 Hillside Ave. • Cincinnati, OH 45233

Tel: 1-800-543-0470 • Fax: 513-941-6913 • www.setcousa.com